

1 Malaysia Cabin

YL Lee PhD, FCSM, HB Koh, Warid Hussin PhD P.Eng
ashmann@ymail.com

Faculty of Civil and Environmental Engineering, UTHM, 86400 Parit Raja,
Batu Pahat, Johor Darul Takzim, Malaysia.

29 June 2015

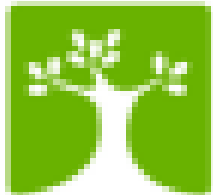

Objectives:

- To share knowledge
- To promote postgraduate studies
- To enhance research and innovation



Outline

- Lowcarbon Malaysia
- Biomass silica ash & aggregate
- CSM & Sustainability
- Waterproofing & thermal insulation
- Challenges

1.net.my

Where Concrete Experts Meet



[Home](#) [About](#)

lowcarbon malaysia

Posted on [June 4, 2011](#) by [ashmann](#)

 

Archives

- [June 2011](#)
- [September 2010](#)
- [March 2010](#)
- [September 2009](#)
- [August 2009](#)
- [July 2009](#)
- [June 2009](#)
- [April 2009](#)
- [March 2009](#)
- [January 2009](#)
- [December 2008](#)
- [October 2008](#)

Meta

- [Log in](#)

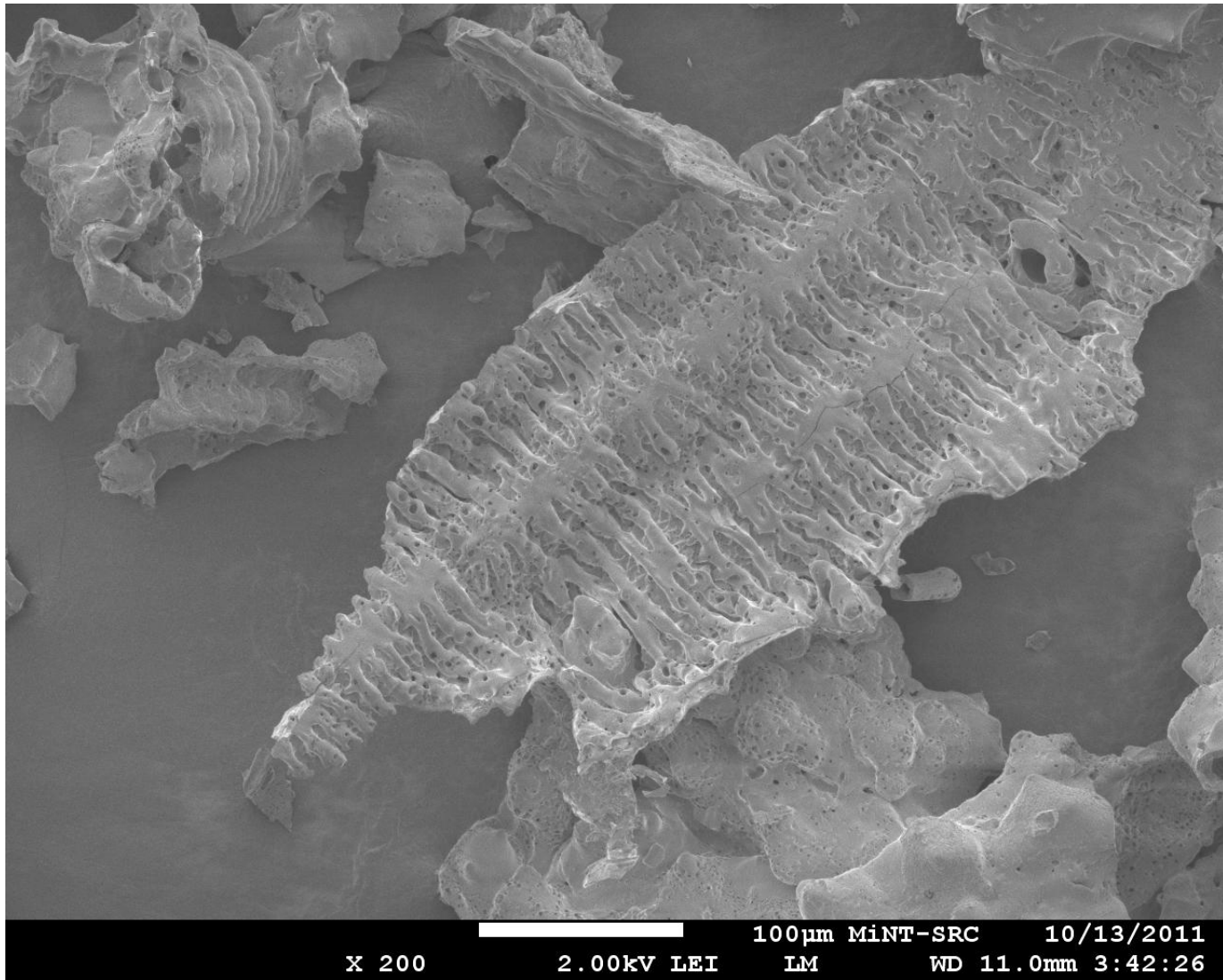

Rice husk ash



Biomass aggregate

POTENTIAL APPLICATIONS OF MICRONISED SILICA

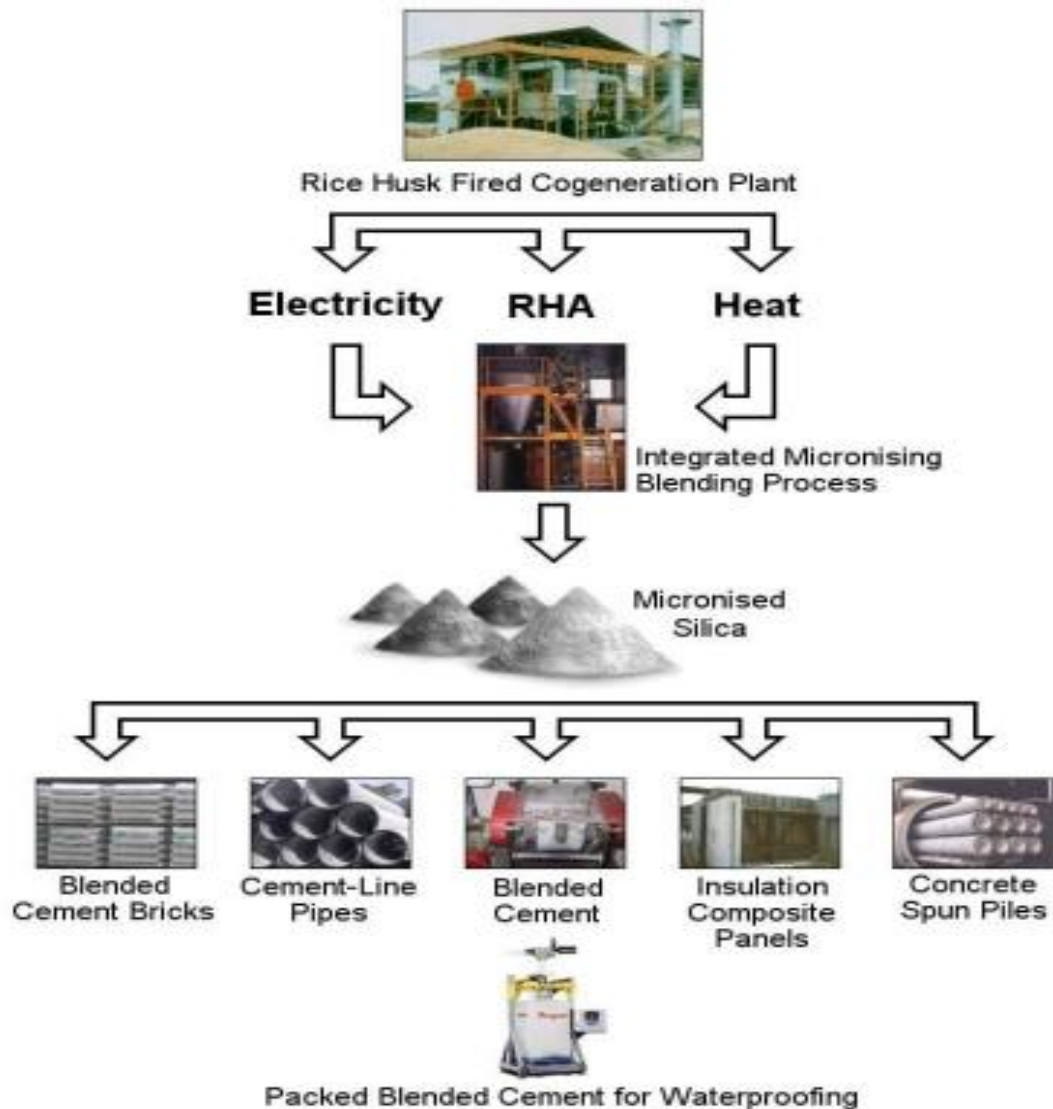



Reactor furnace for amorphous biomass silica ash synthesis

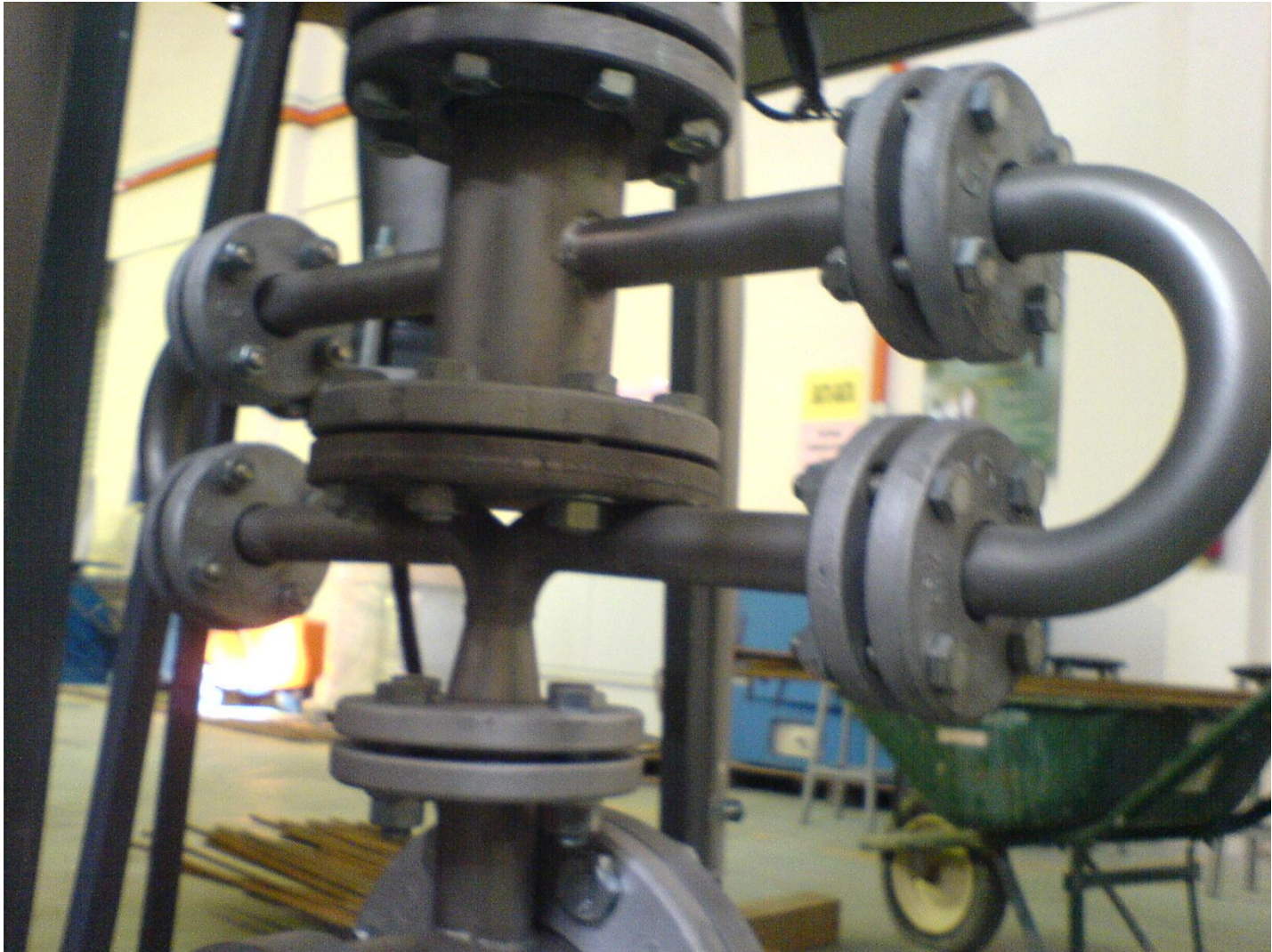

Opposed Jet Mill micronising chamber

RHA

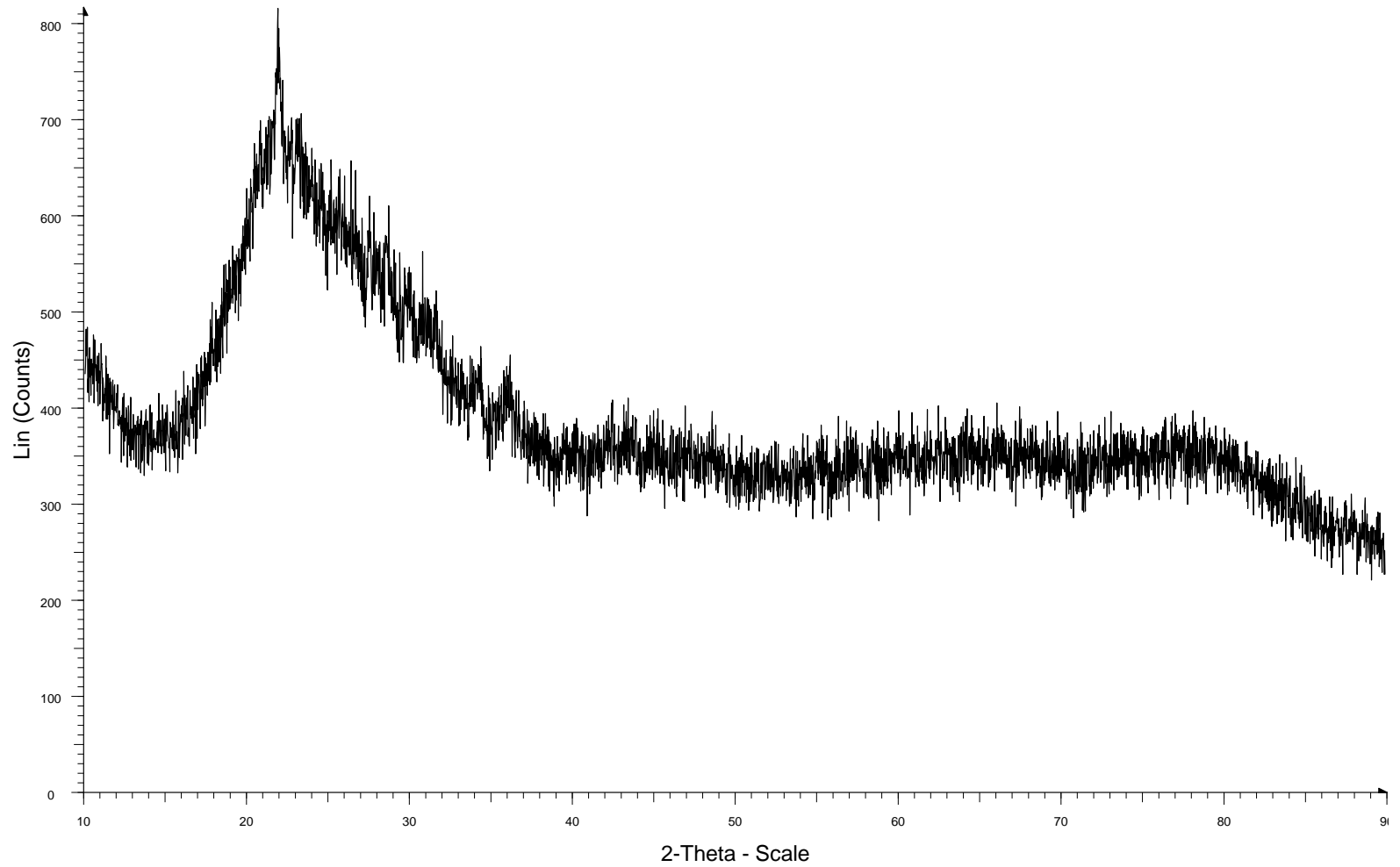

RHA - File: RHA.raw - Type: 2Th/Th locked - Start: 10.000 ° - End: 90.006 ° - Step: 0.020 ° - Step time: 15.4 s - Temp.: 25 °C (Room) - Time Started: 10 s - 2-Theta: 10.000 ° - Theta: 5.000 ° - Anode: Cu - WL1: 1.540
Operations: Import

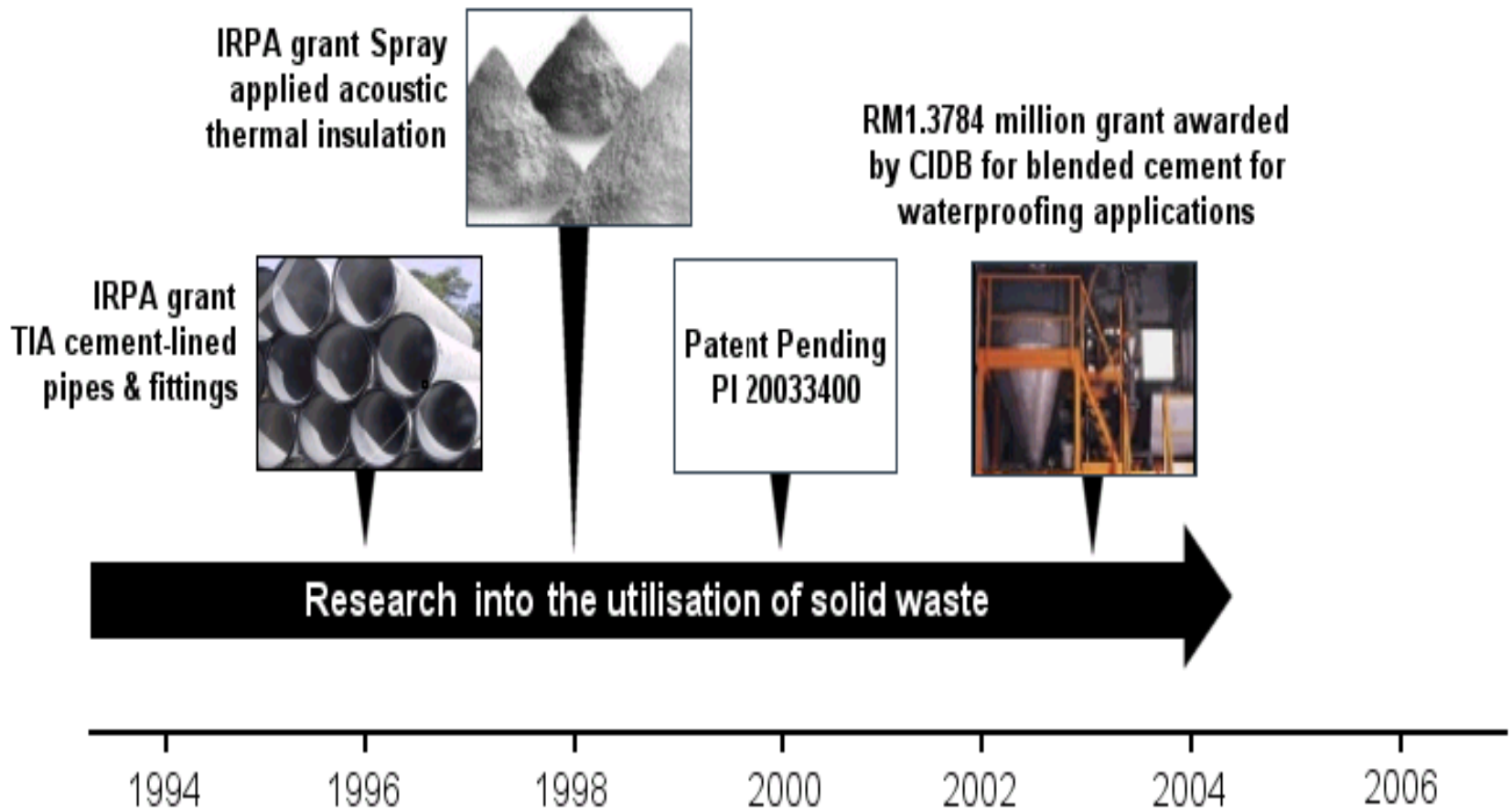

Milestone achievement for the exploitation of solid wastes in construction



Bulk handling of biomass silica



Bulk handling of biomass silica



Prepacked biomass silica

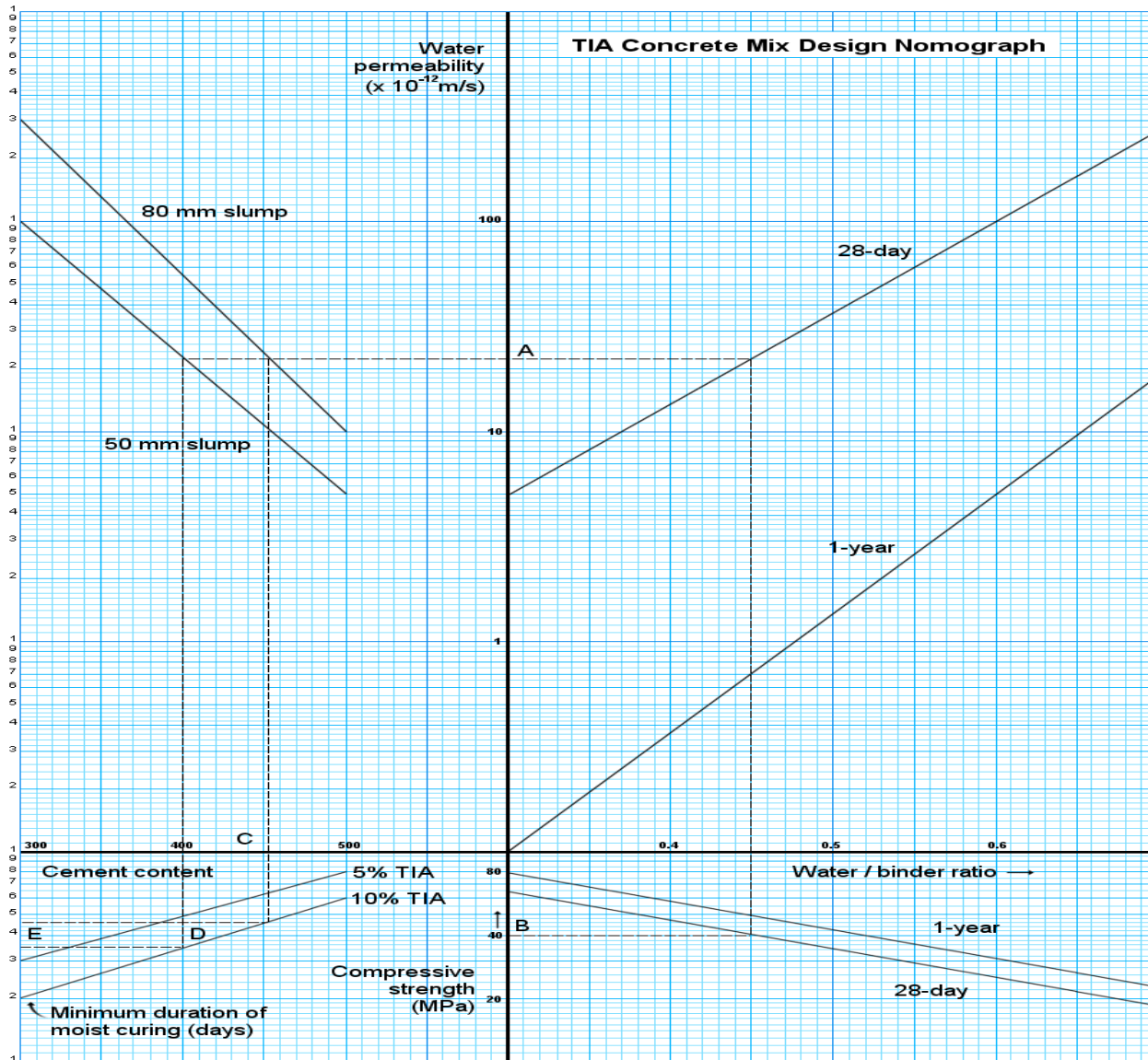

Technology Showcase



Within 3 days, 1800m^3 of foamed concrete (6m high) was cast. The total volume was about 180 units of low cost houses.

Knowledge transfer

- A method of synthesising biomass silica ash and aggregate
- Carbon sequestration media
- Industrialised construction system



On-site production
of KUIKcrete



Density monitoring of foamed concrete



Foam Generator and Mixer for Kuikwall

Demo plant in KL



Research opportunities



KUIK Block for soft soil subbase system



Test site at RECESS, UTHM

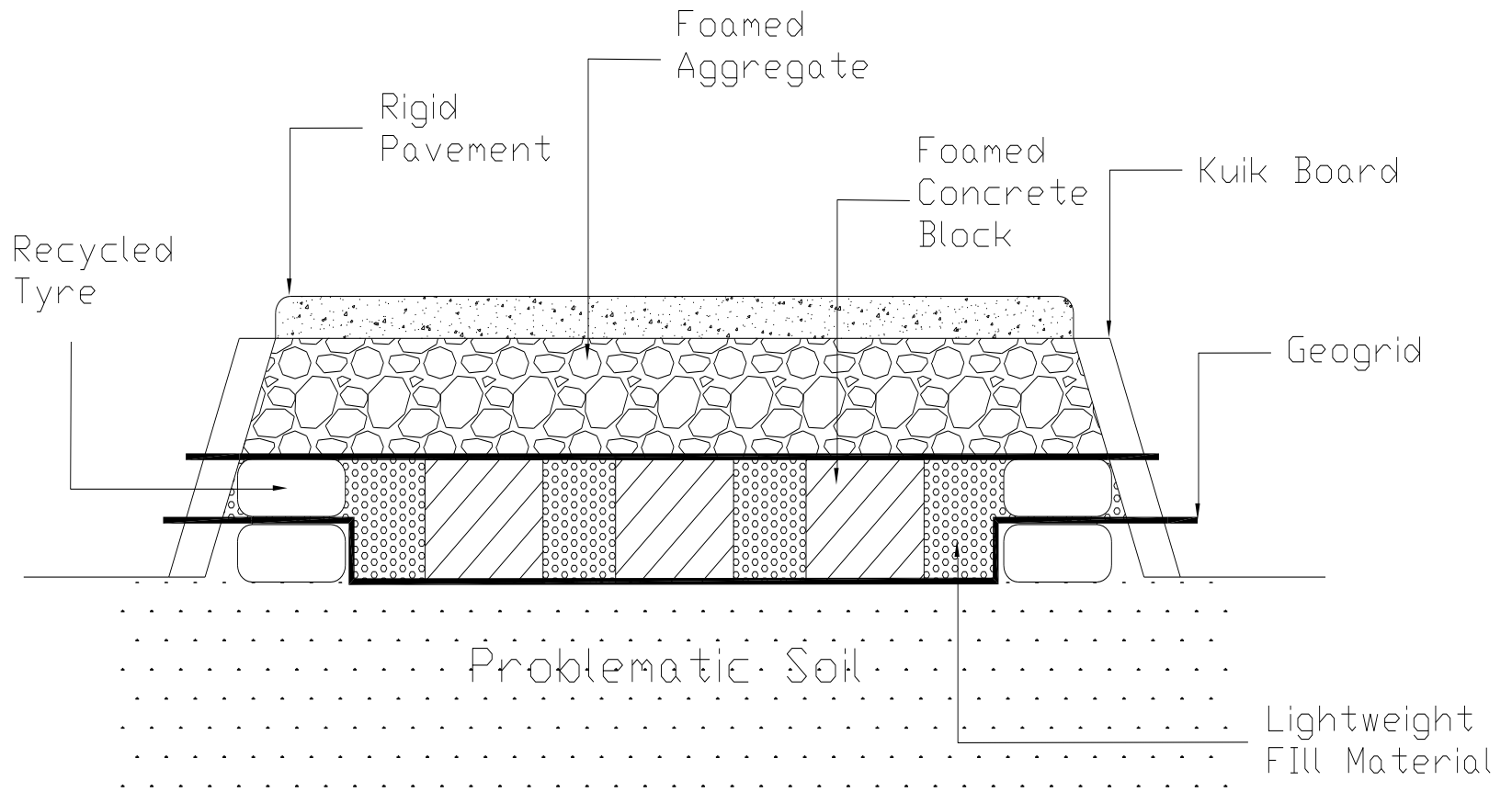

Soft soil subbase system (S3)

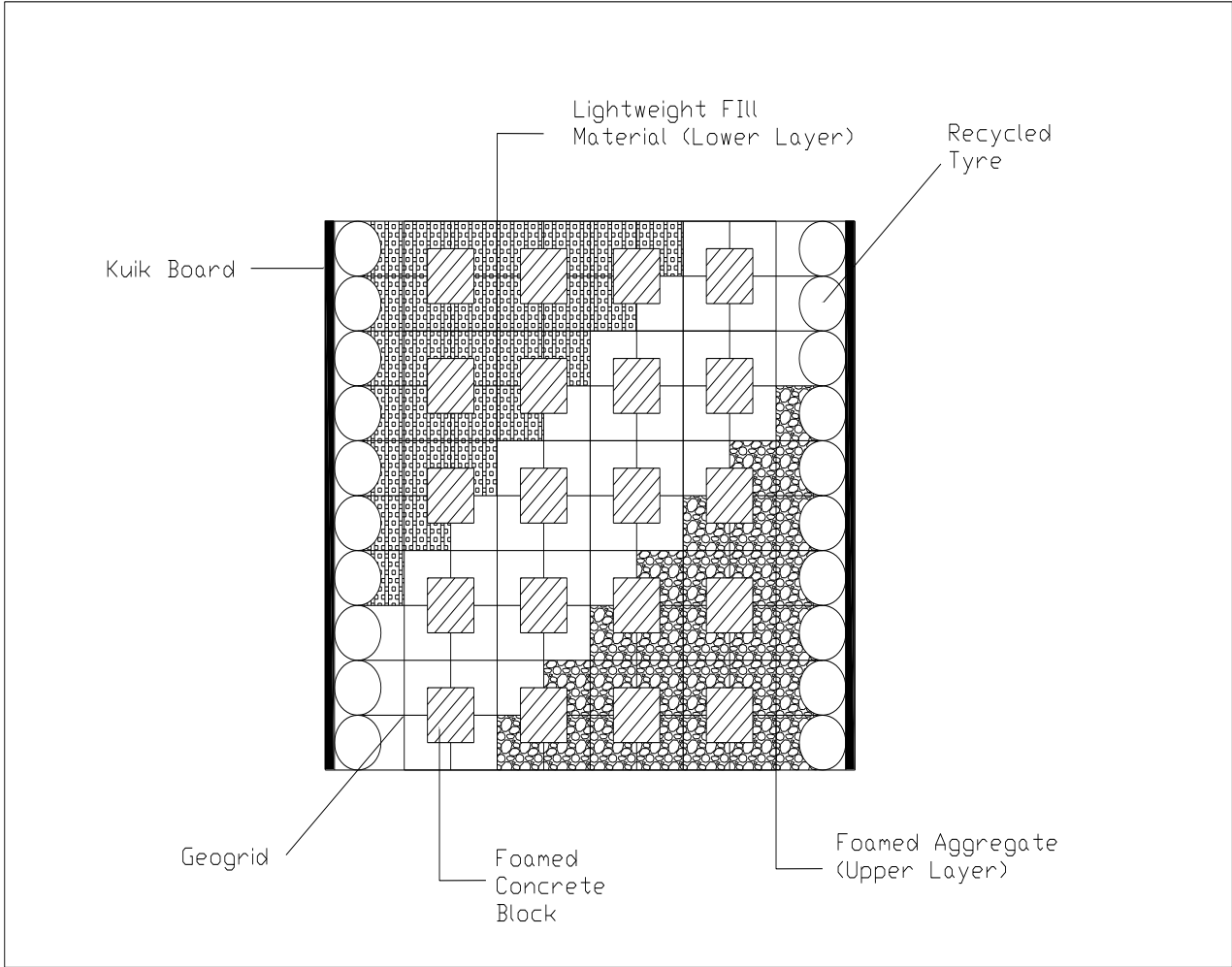

Soft soil subbase system (S3)

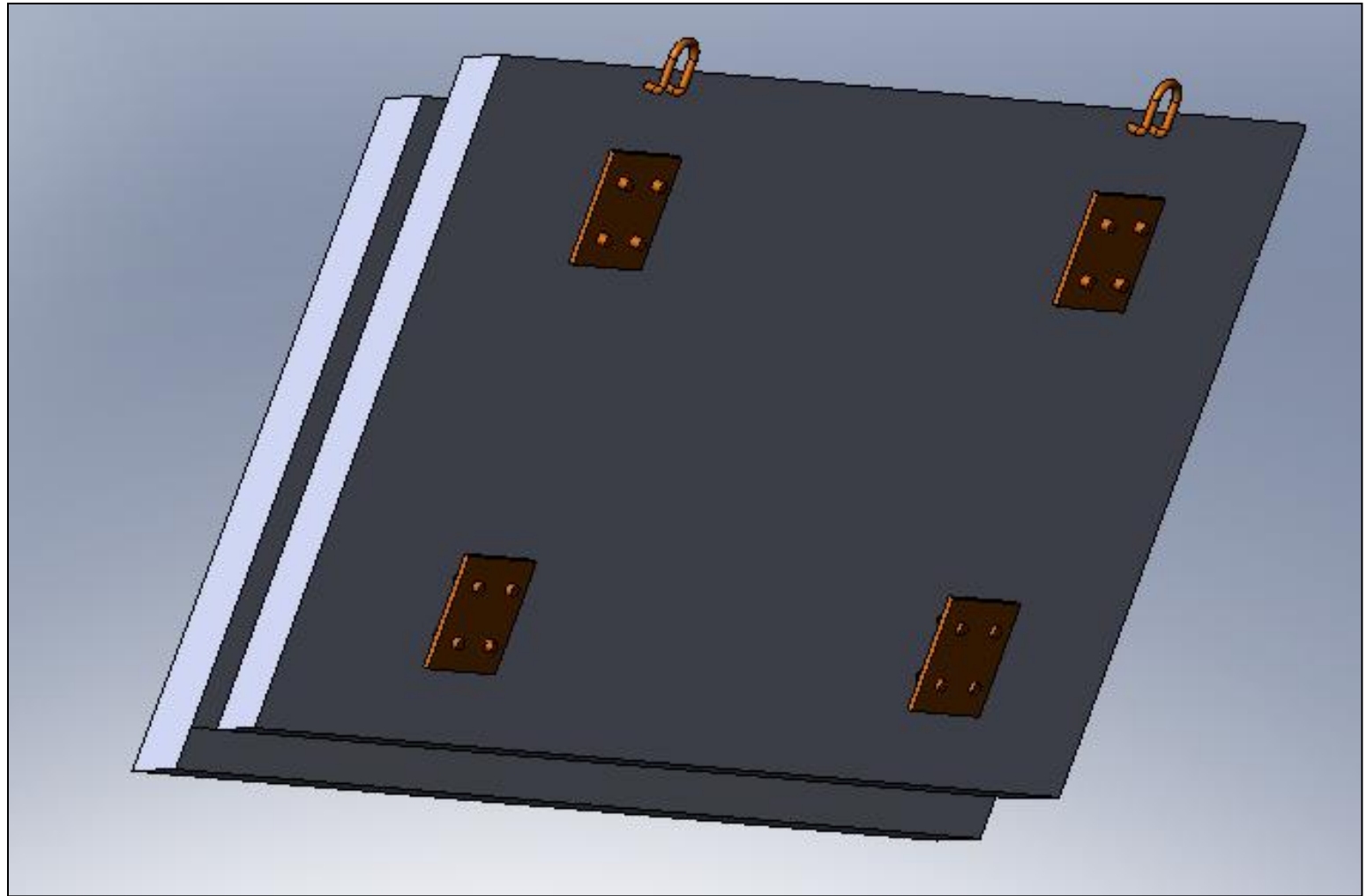

KUiK board



S3 experimentation



S3 subgrade ready for pervious concrete pavement



KUikWall in UTHM



KUIK Cabin



KUiKwall at UTHM



KUiK formwork with profiled expanded polystyrene panels



KUiKwall
Materials formulation



Fine sand for KUiKcrete

KUiK Home construction process



Mixer truck



Cement & sand is batch in mixer truck



Foam batching in mixer truck



Measuring Density



Mixer truck to concrete pump



Casting of foamed concrete into system formwork



1

KUiK Home Casting







KUiK home showcase



KUiKwall



KUikwall in highrise construction

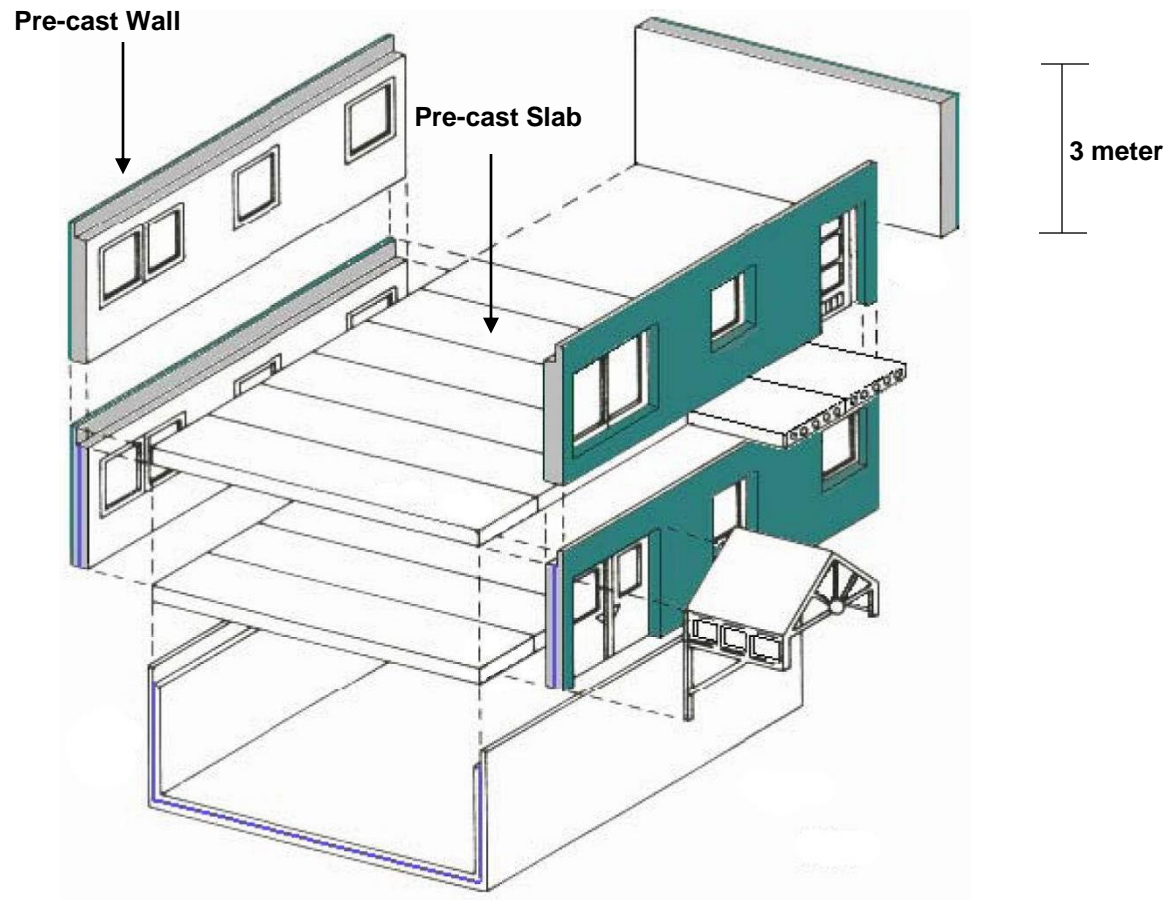

KUiK Cabin

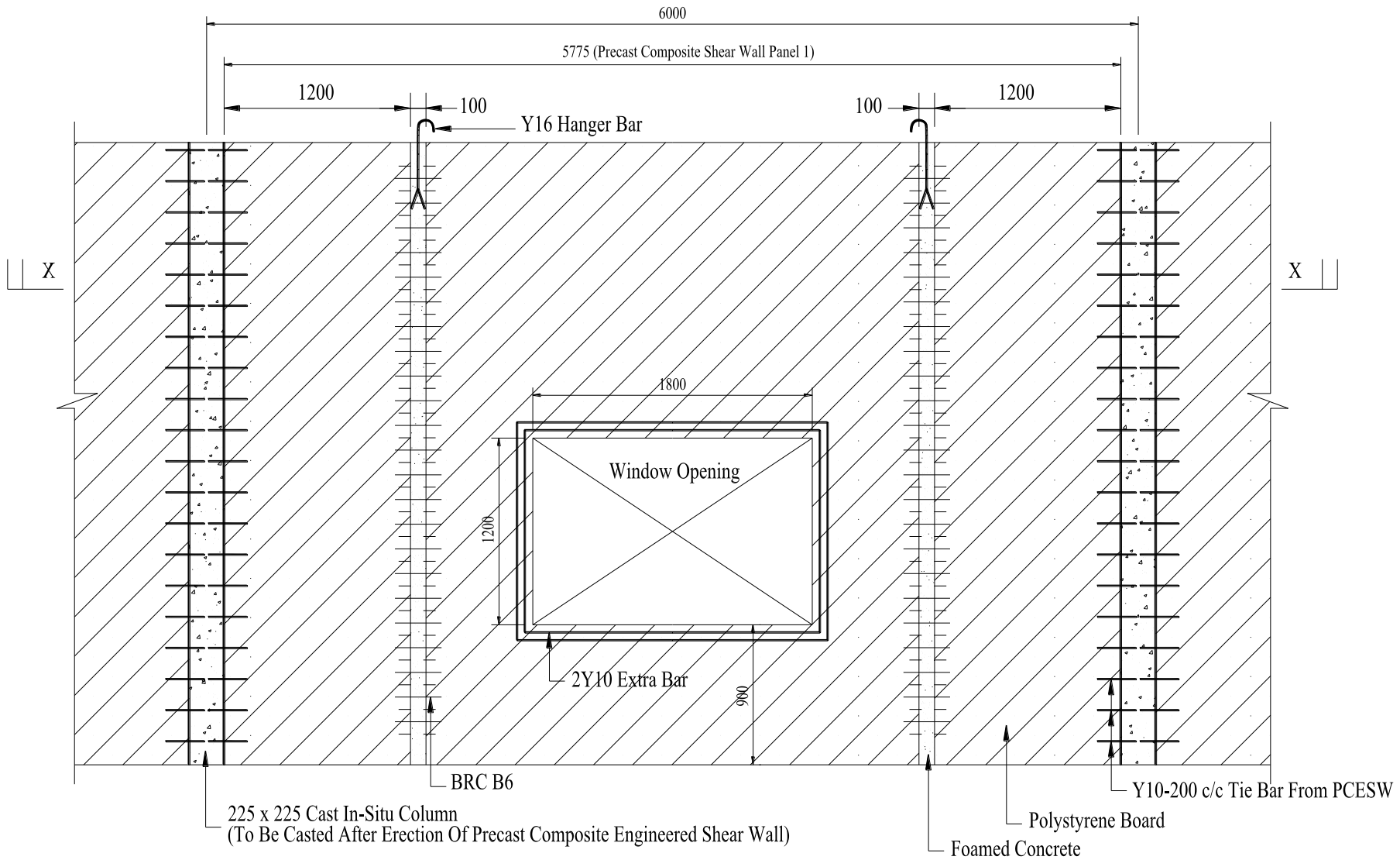

TYPICAL SECTION DETAIL FOR PRECAST COMPOSITE SHEAR WALL PANEL 1 (PCSW1)

SCALE: 1:25



KUiKwall component tested
for load bearing capacity

Prestressed base frame

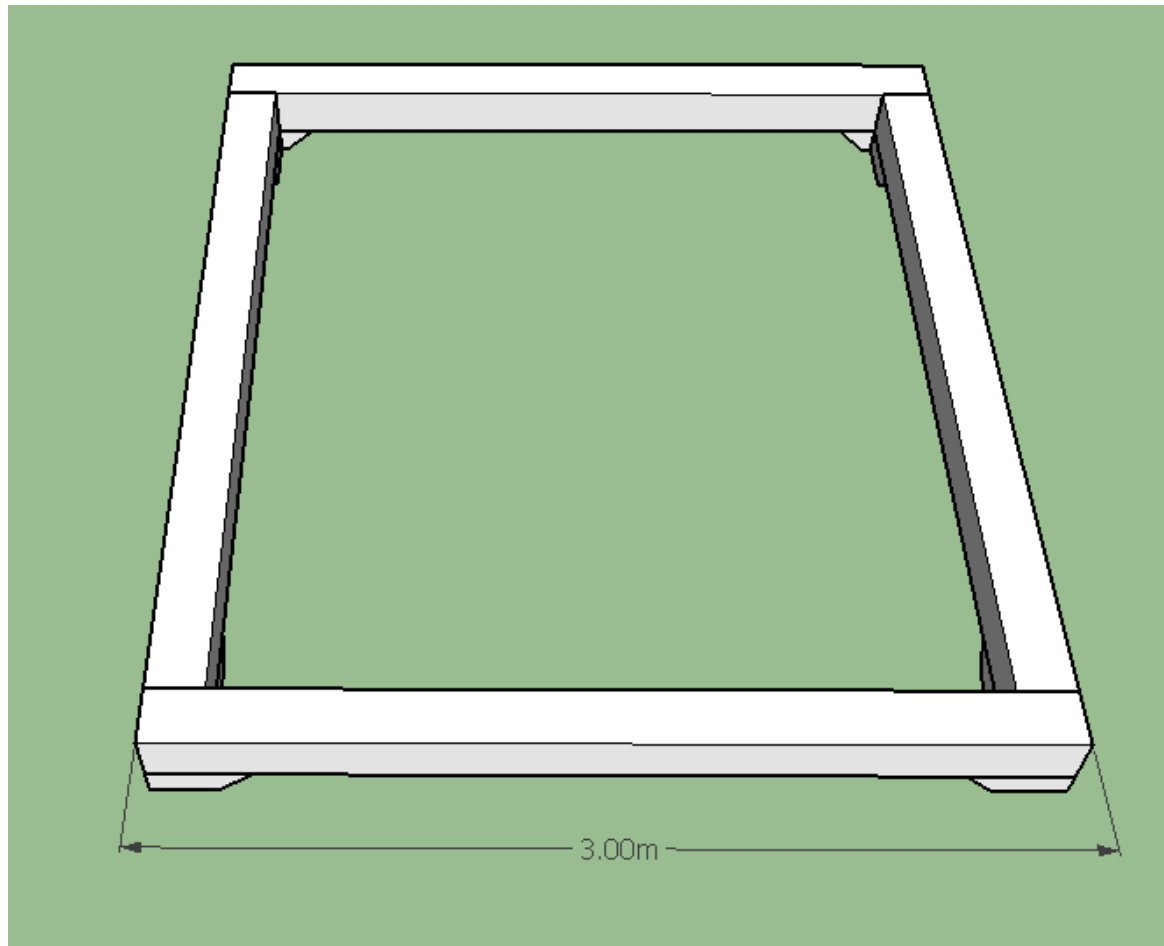

Prestressed base frame

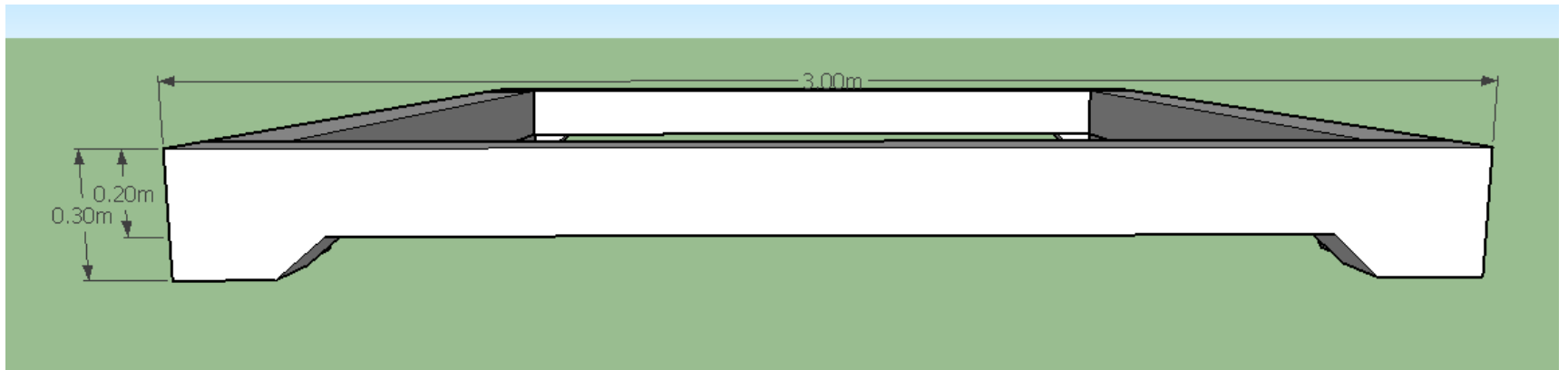

Provision for column

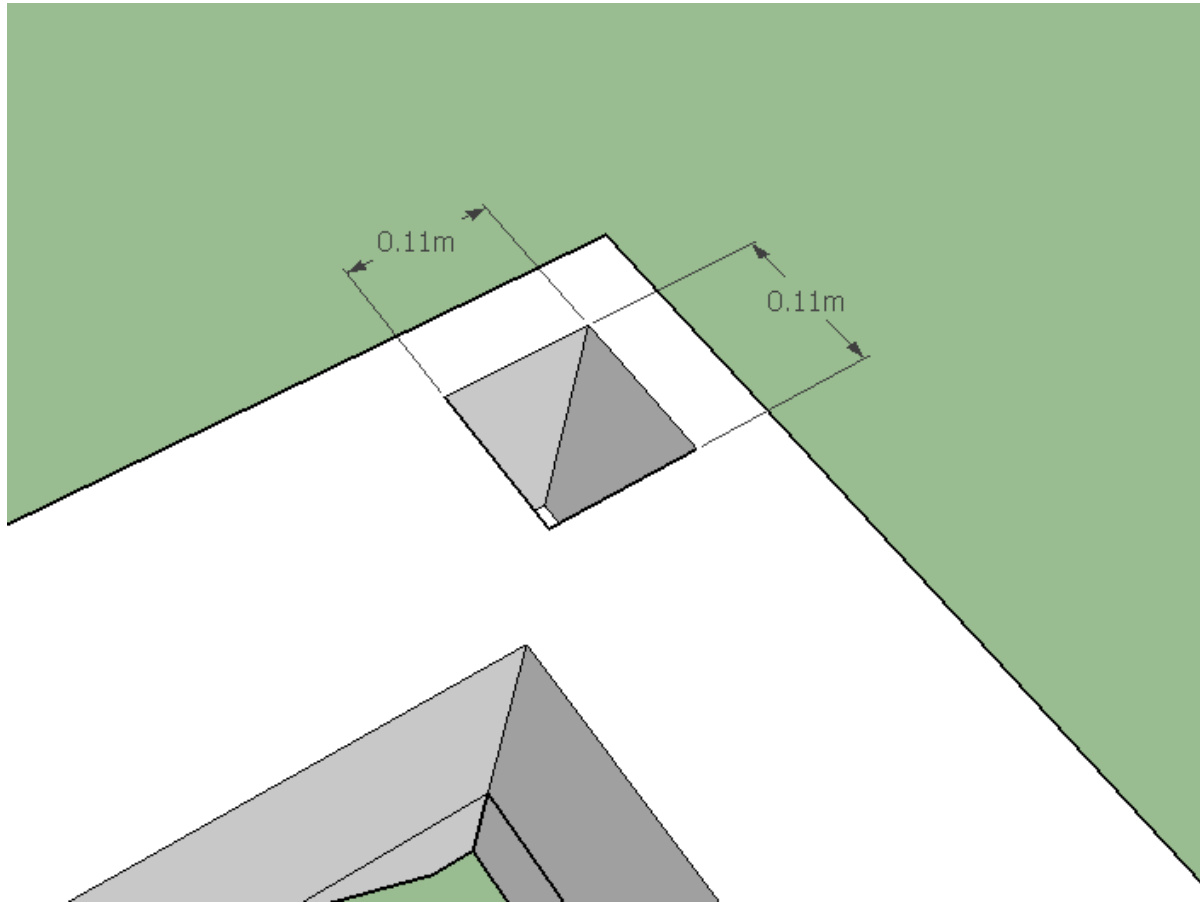

Prestressed column installation

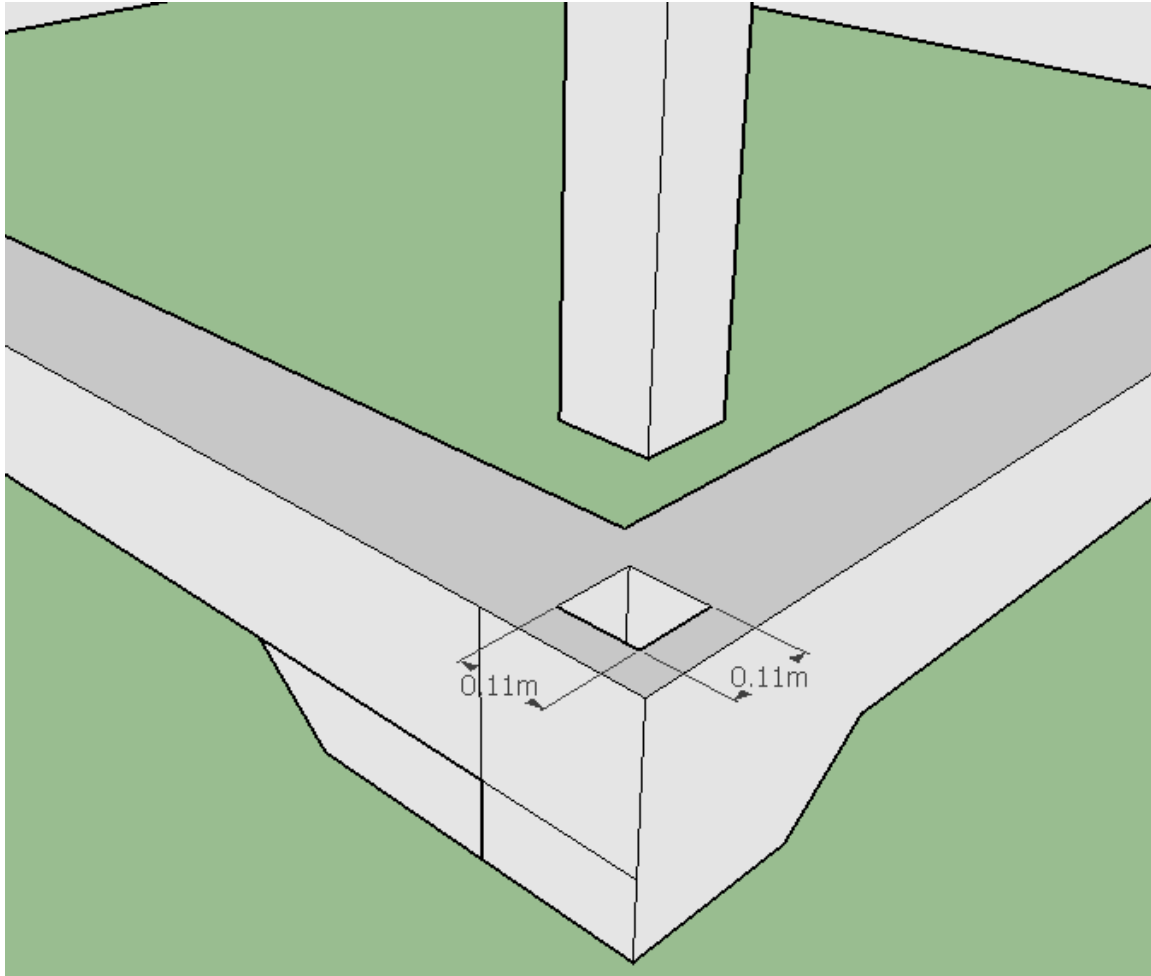

Installation details

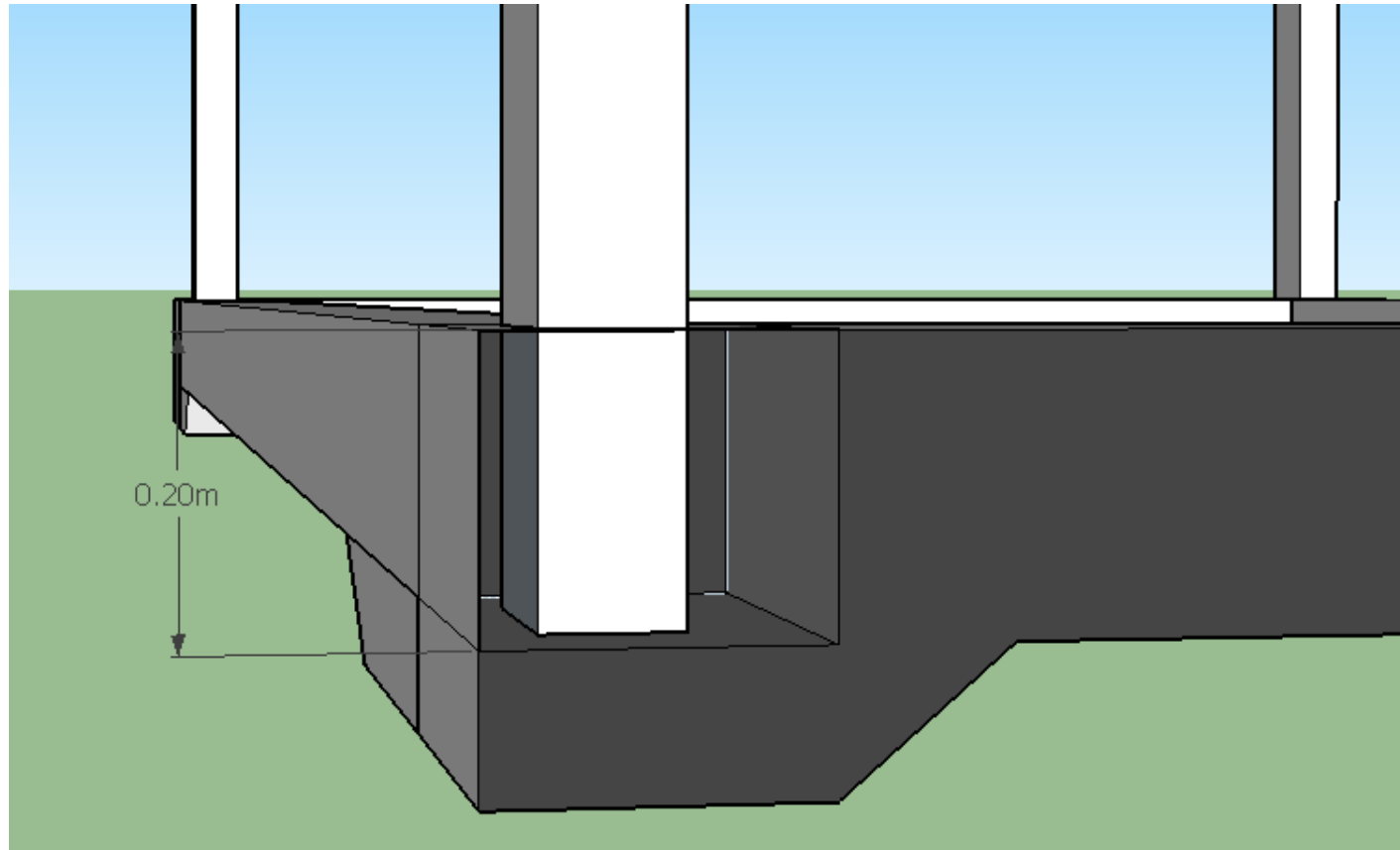

Columns before bracing

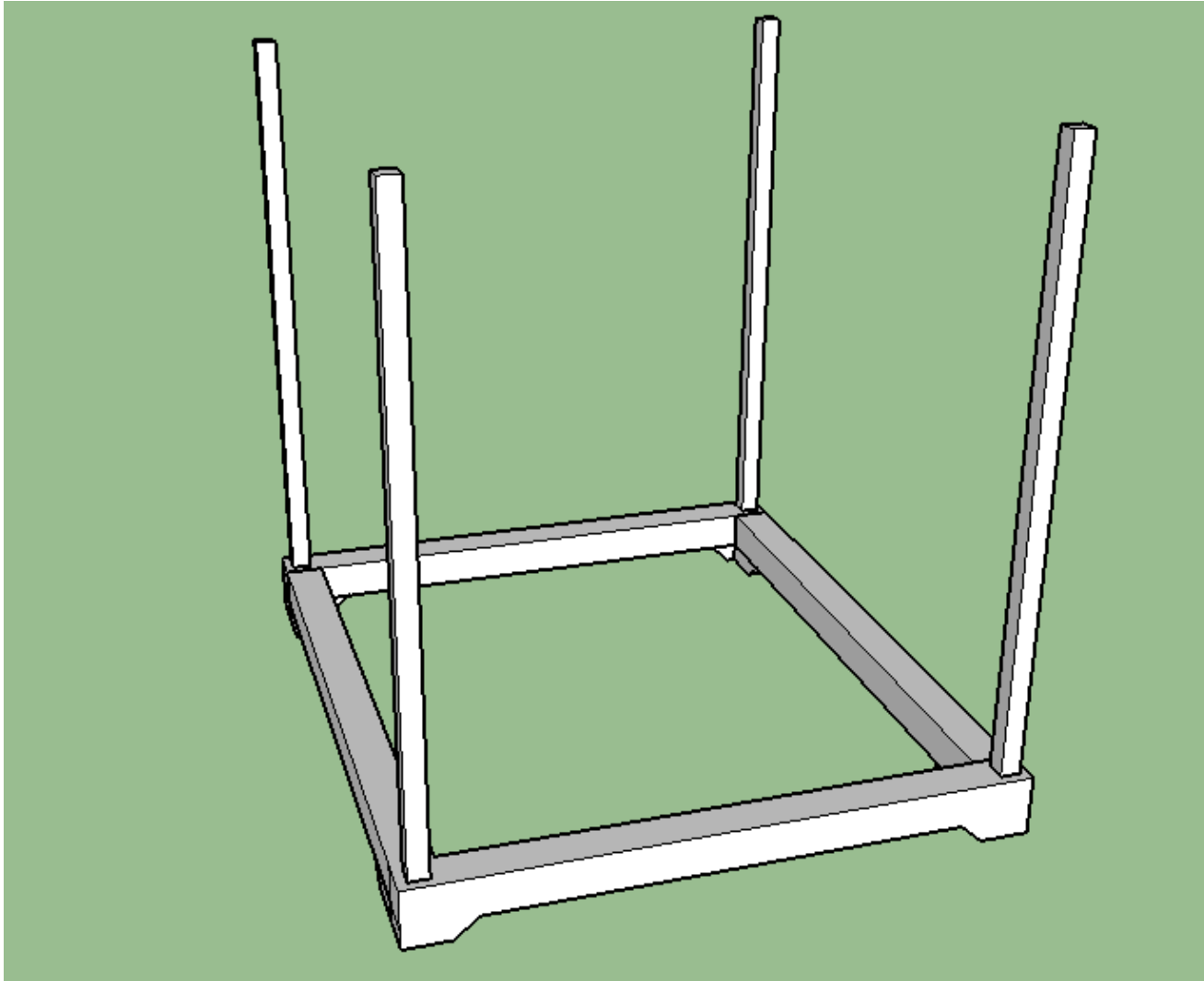

Columns after bracing

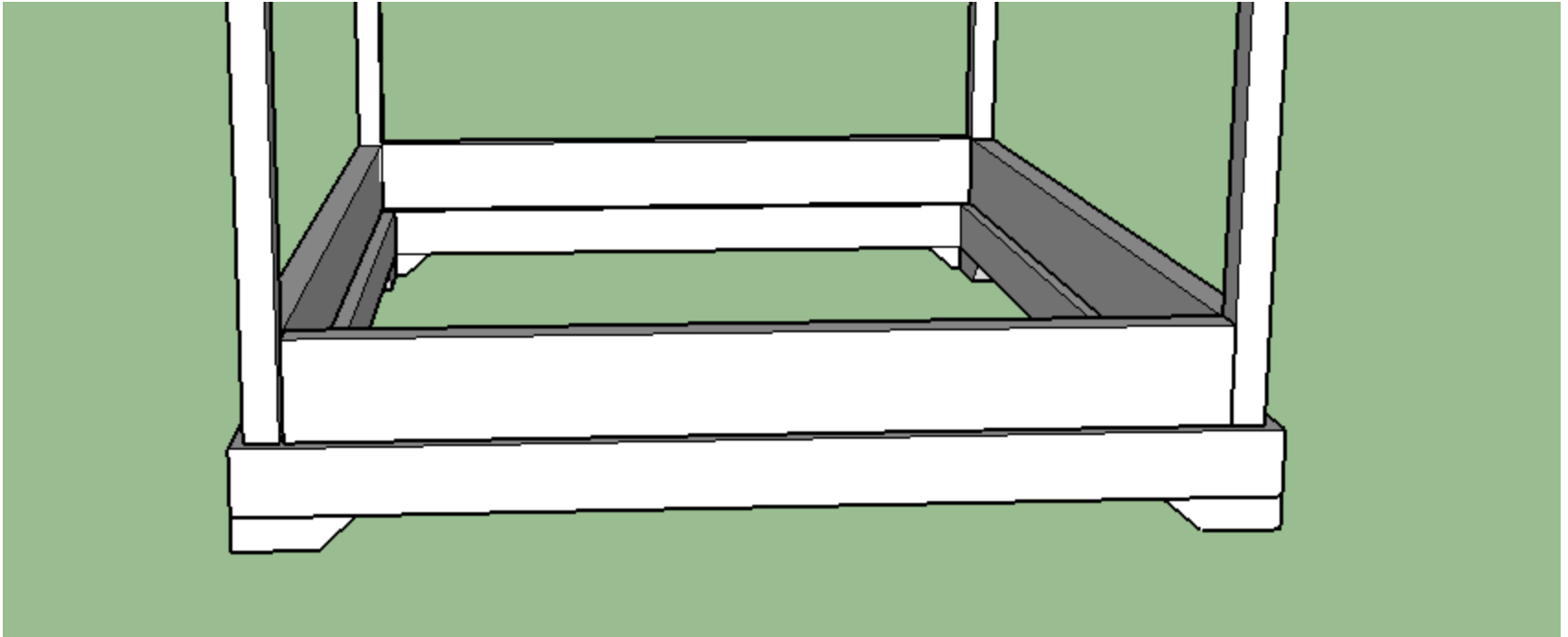

Braced columns to be grouted/welded

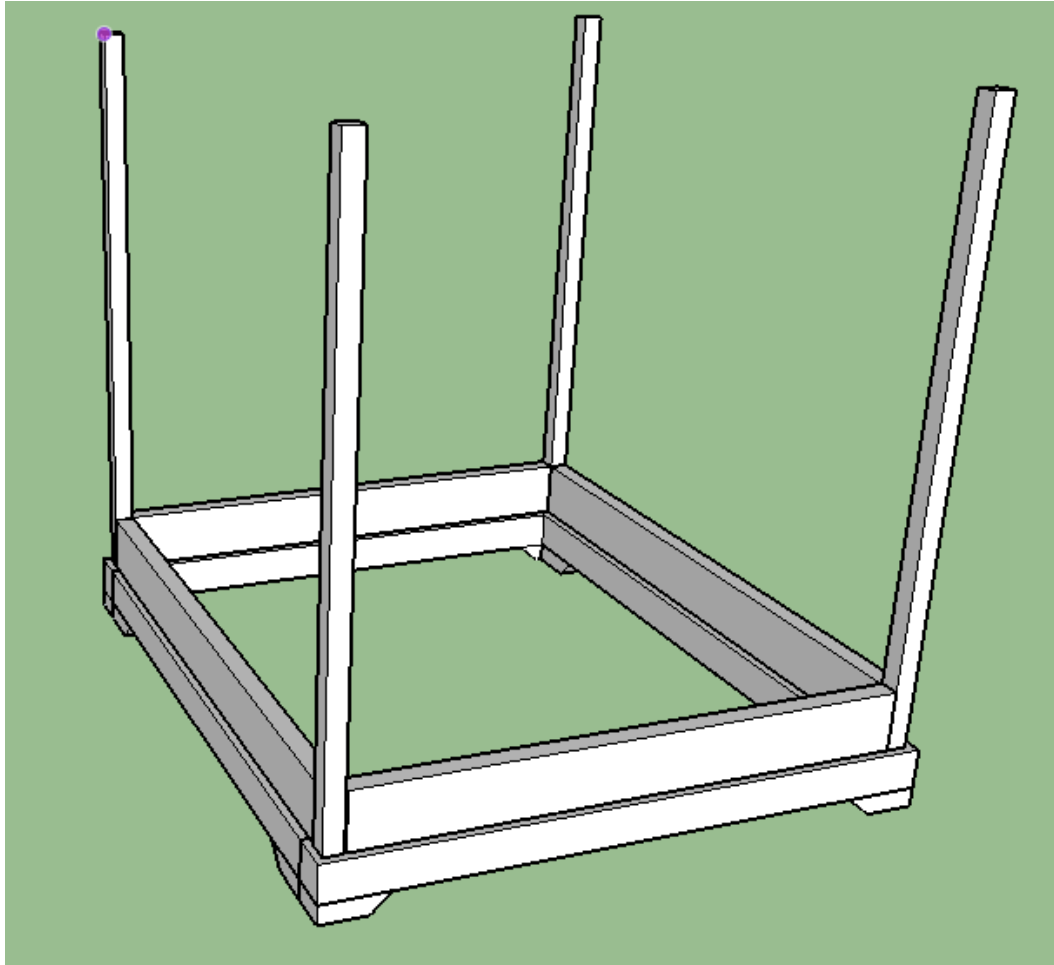











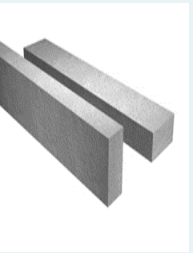

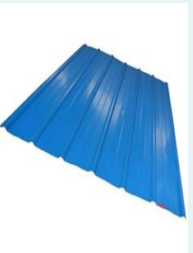
Materials Schedule

CEMENT	INTERLOCKING BLOCKS	PRECAST CONCRETE	PRESTRESSED PRISM	WOOD BEAM	ZINC ROOF	WATER
						
4 BAGS	AROUND 1068	1 PIECE	10 PIECES	8 PIECES	3 PIECES	ADEQUATELY

INTERLOCKING BLOCK DIMENSION

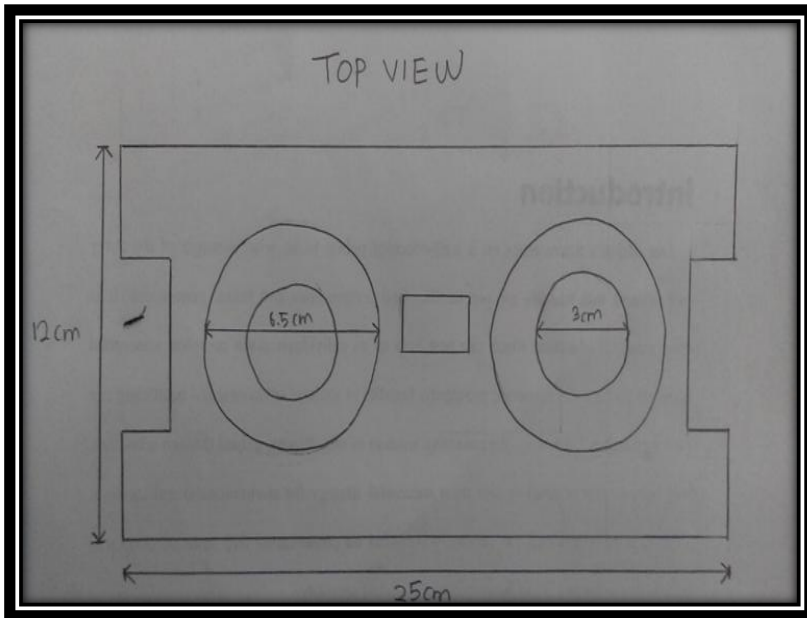

TOP VIEW

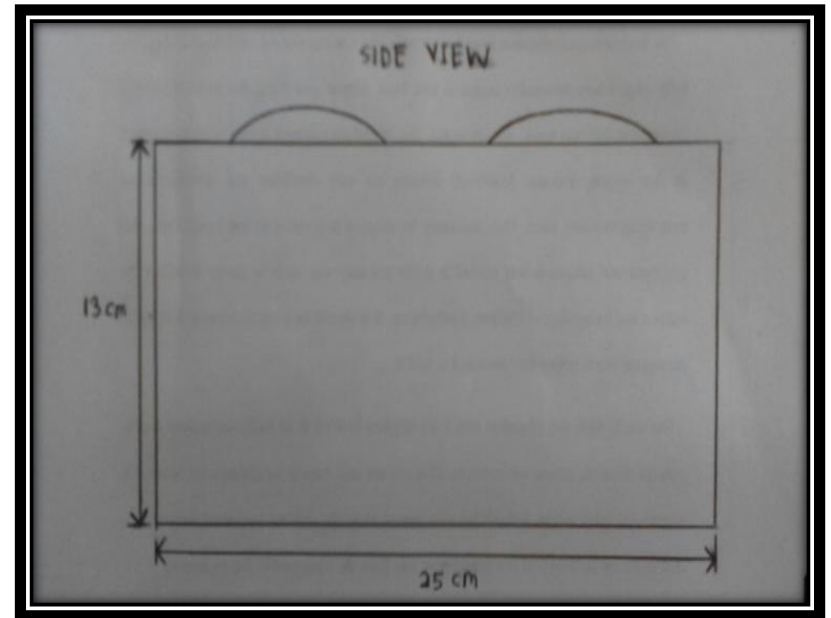

SIDE VIEW

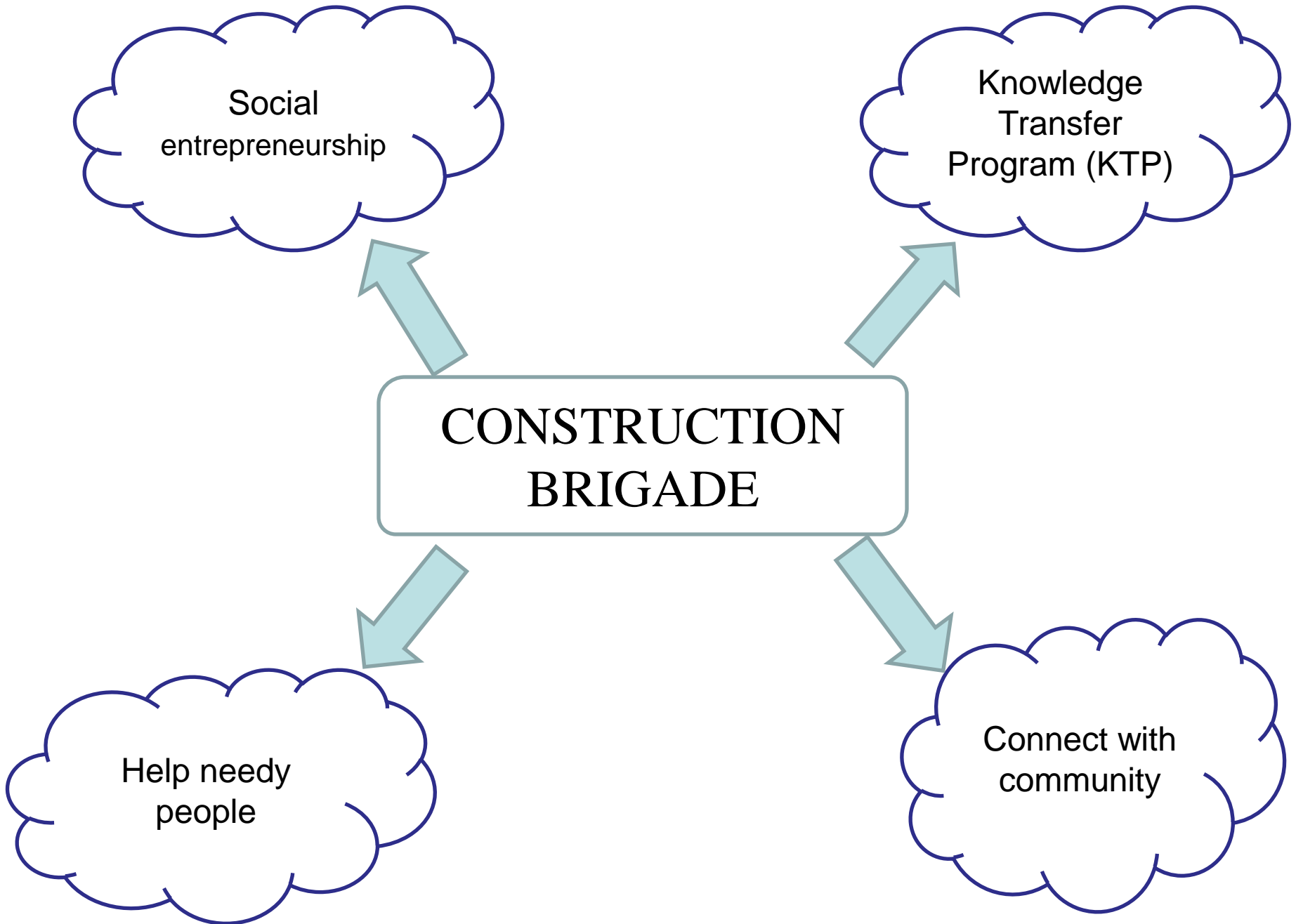

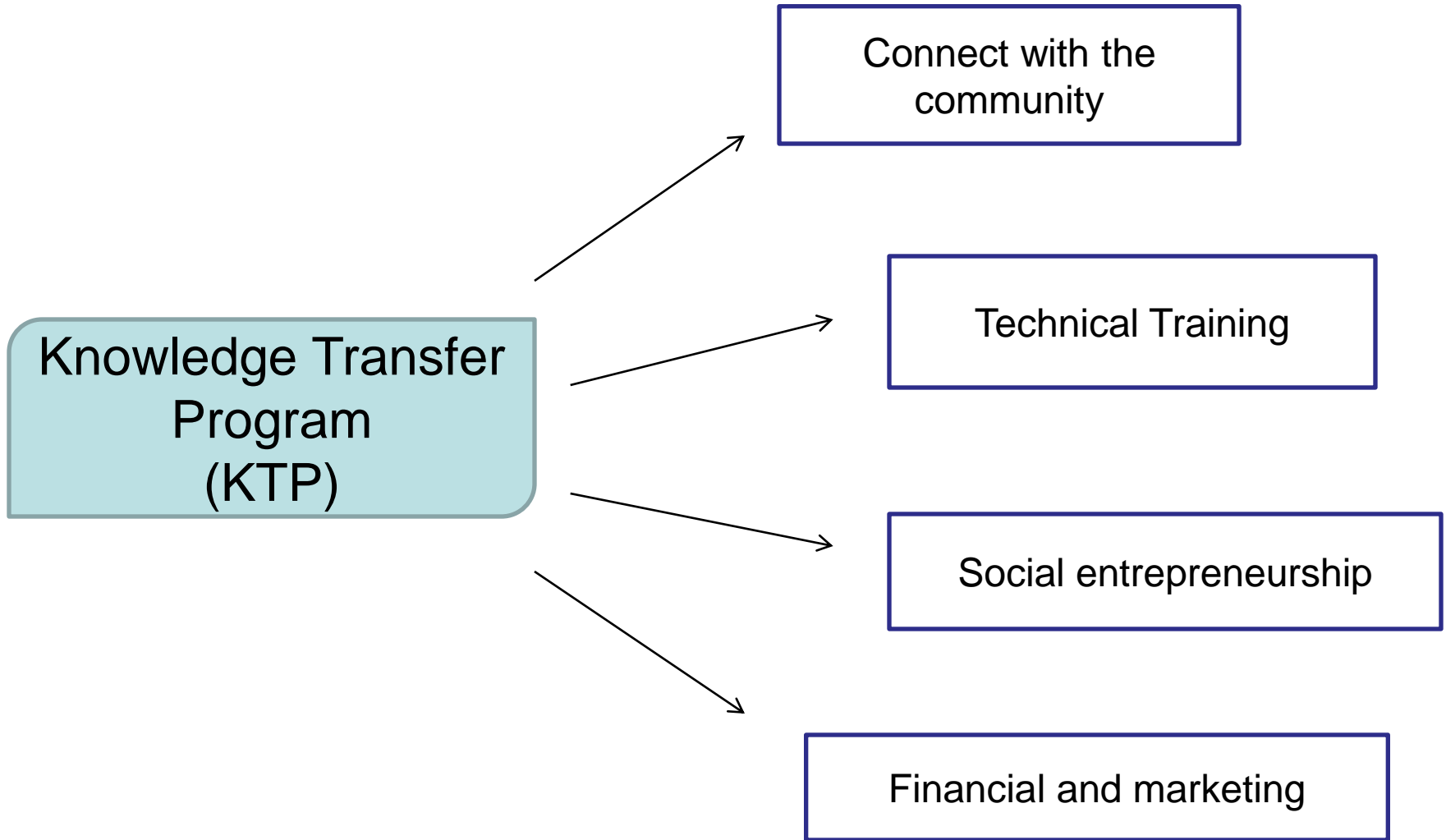



















A photograph of a construction site for a road on peat. The foreground is a gravel surface. In the middle ground, there is a concrete wall and a stack of concrete blocks. The background shows a dense forest of green trees.

Industrialised Construction System for Road on Peat

Lee Yee Loon
Chong Chee Hing
Koh Heng Boon
Mohamad Ali Fulazzaky
Soo Juan Fong

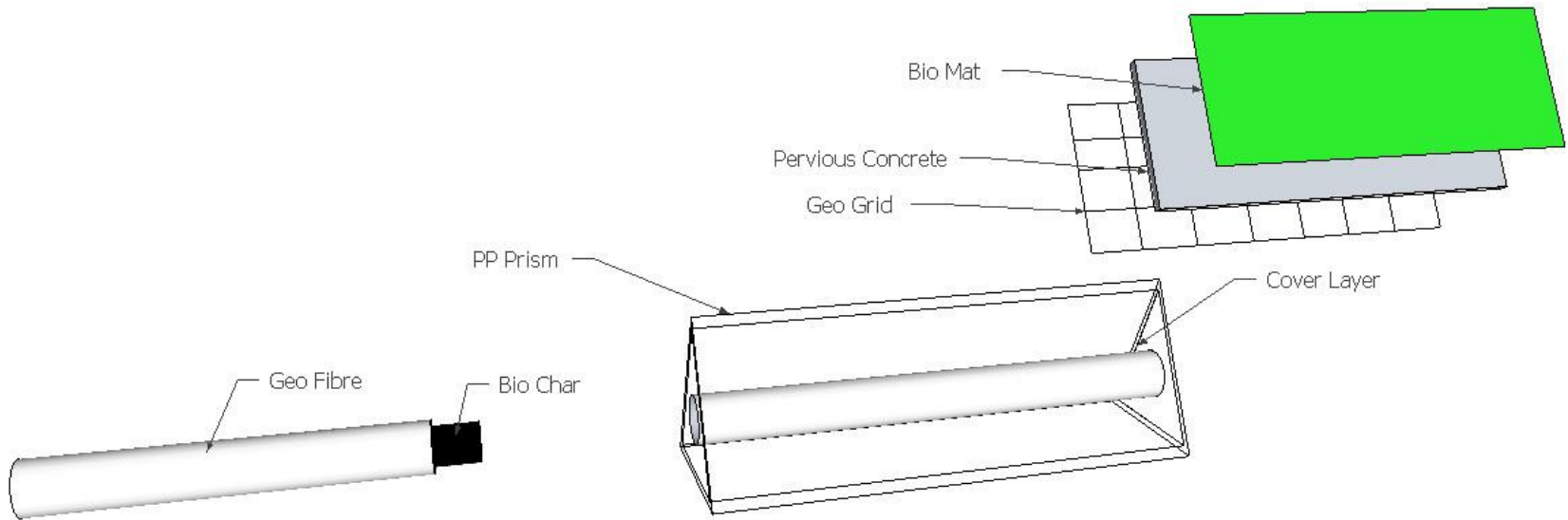

Subbase drainage system with geogrid and foamed concrete

Installation on site



UTHM team





Tan Sri Yong fascinated by PinSpace concept



MVI_0582

KUiK wall attracting angel investor

NDT on KUIKBlok





Researcher at work



Ampang Putra Site visit

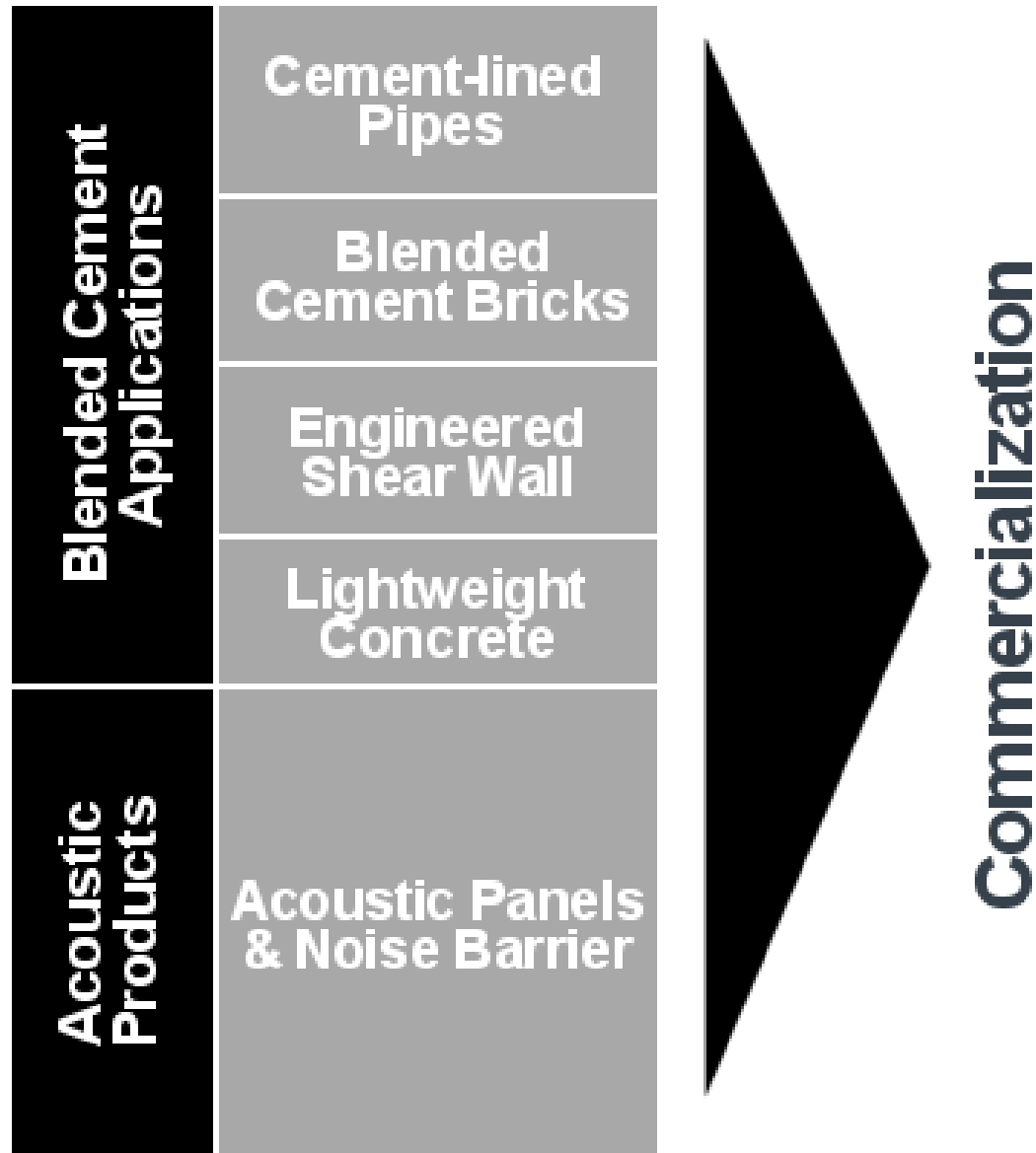

Research products identified for commercialisation

Environmental Friendliness

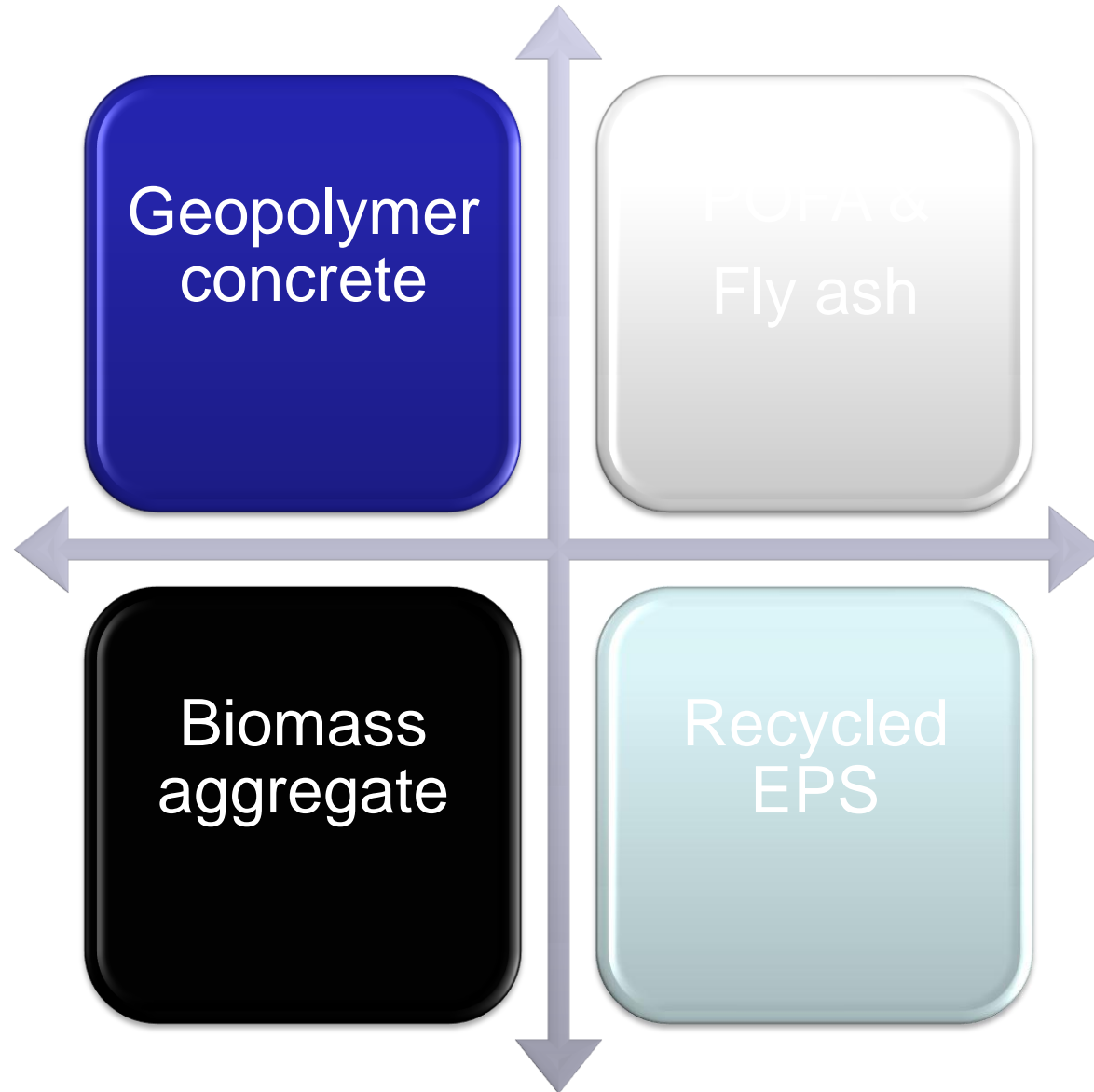

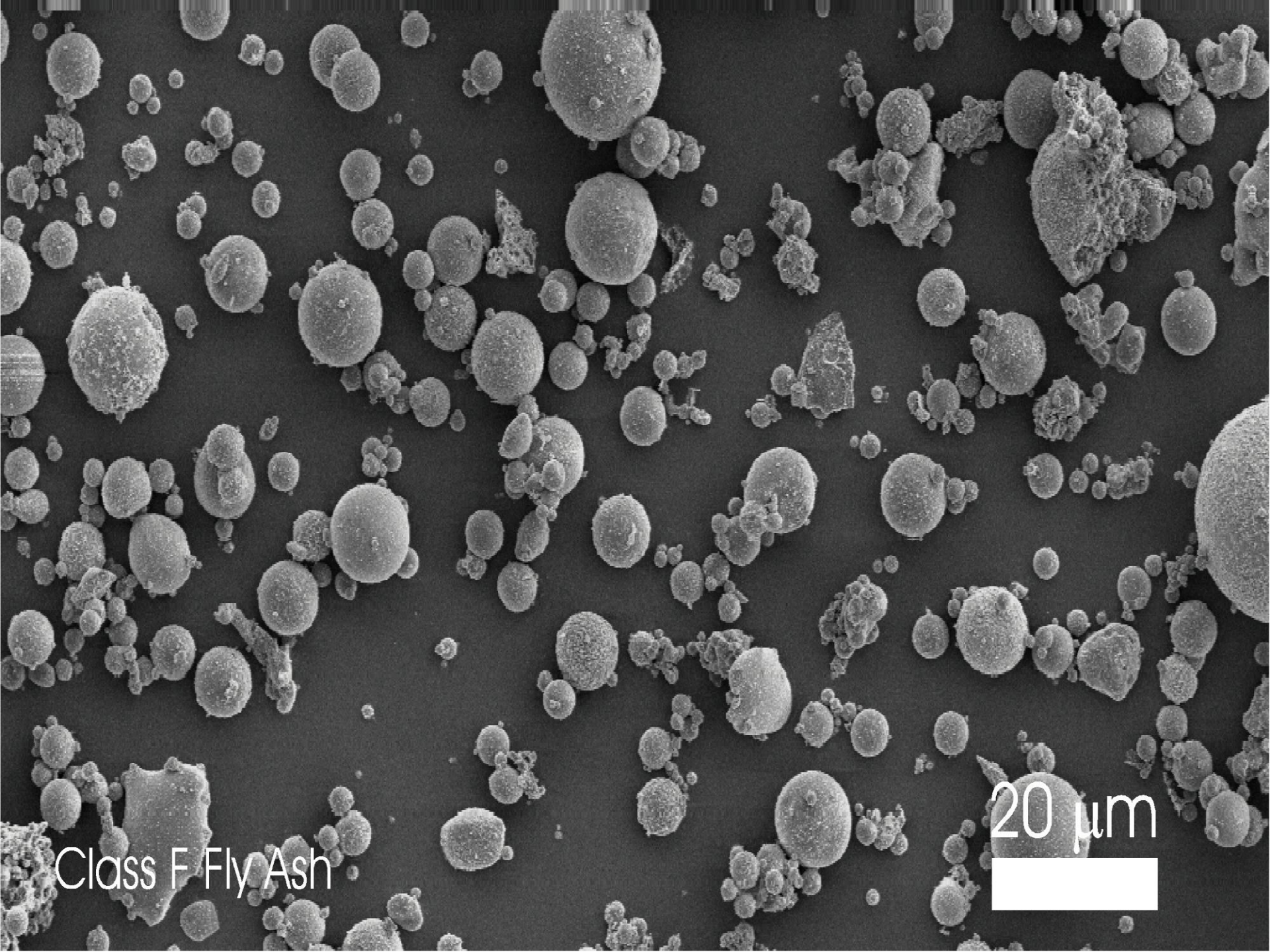

Class F Fly Ash

20 μm

Fly Ash Composition

as determined by XRF (by mass %)

Oxides	Batch I	Batch II
SiO₂	53.36	47.80
Al₂O₃	26.49	24.40
Fe₂O₃	10.86	17.40
CaO	1.34	2.42
Na₂O	0.37	0.31
K₂O	0.80	0.55
TiO₂	1.47	1.33
MgO	0.77	1.19
P₂O₅	1.43	2.00
SO₃	0.20	0.29
Cr	0.00	0.01
MnO	0.00	0.12
LOI^{*)}	1.39	1.10

Permeability of Geopolymer Concrete (Siddiqui 2007)

Compressive Strength (MPa)	Permeability of Geopolymer Concrete (m/s)	Permeability of Portland Cement Concrete (m/s)
40	9.6×10^{-12}	11.0×10^{-12}
50	7.9×10^{-12}	9.7×10^{-12}

Compressive Strength and Slump



Series	Compressive Strength (MPa)	Slump (mm)
GC-I	40	240
GC-II	60	220

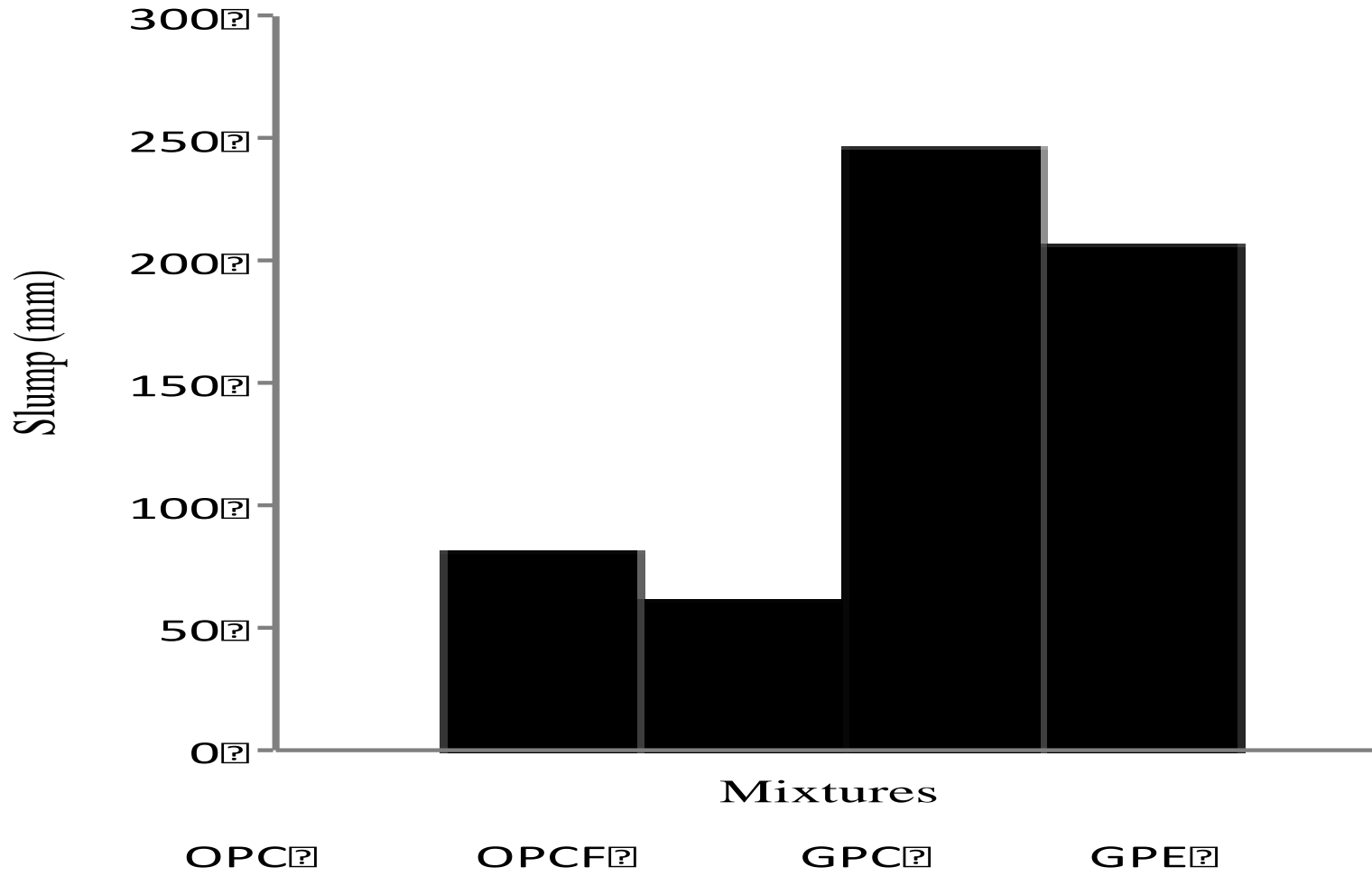

Fig. 1. Workability of OPC and GPC

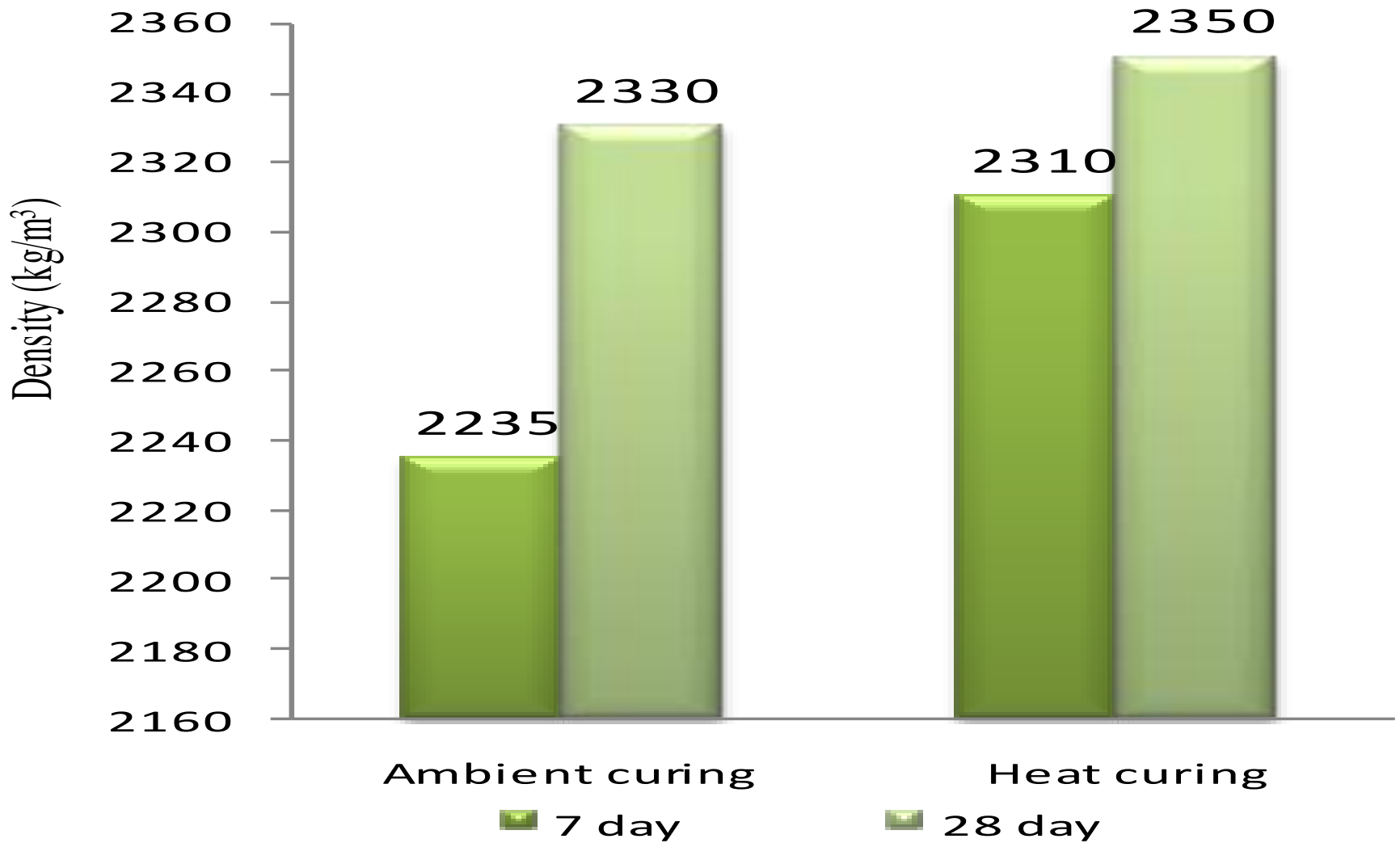

Fig. 2.Variation in Density of GPC

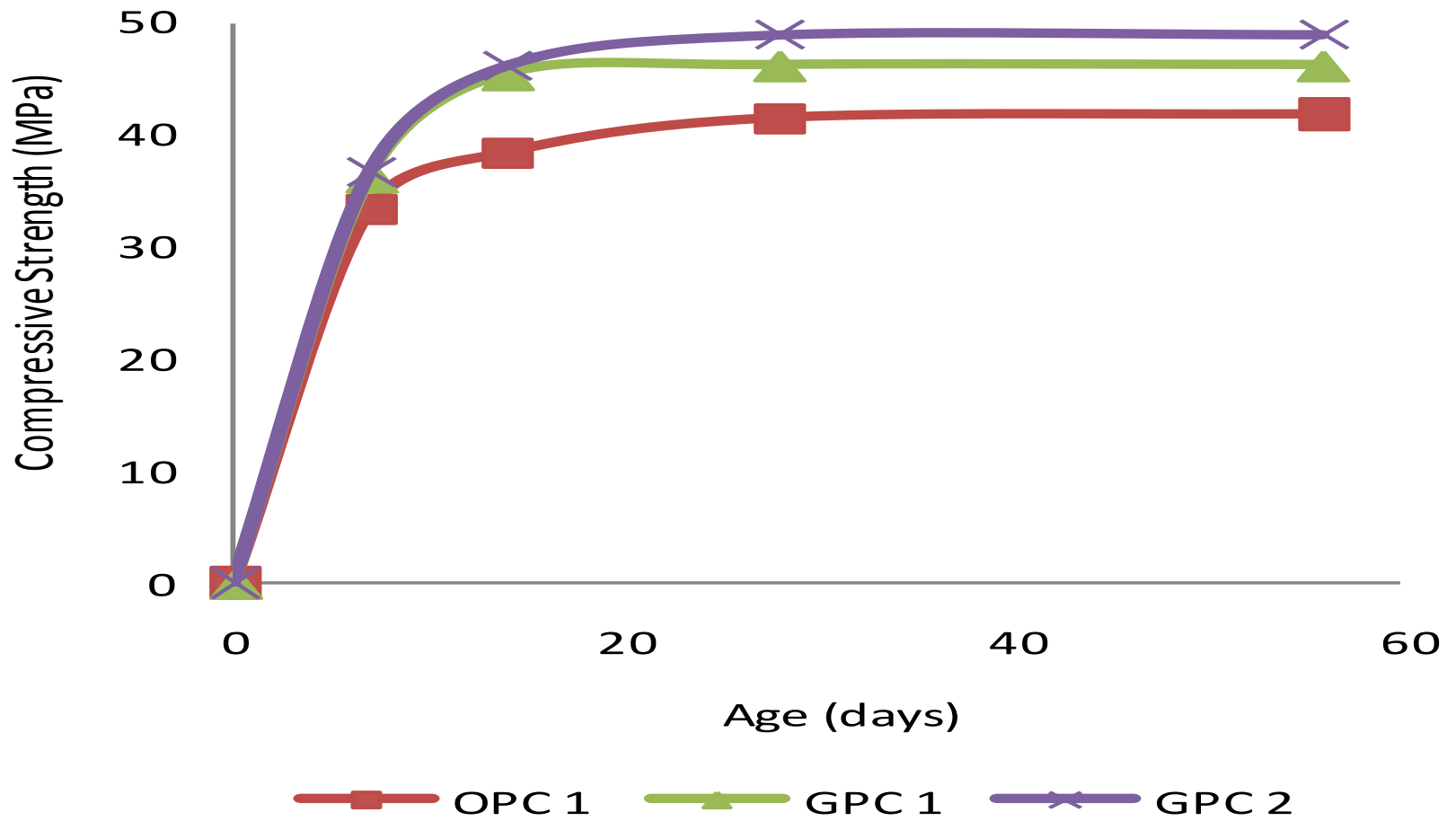

Fig. 3 (a). Ambient curing of concrete specimens (series I)

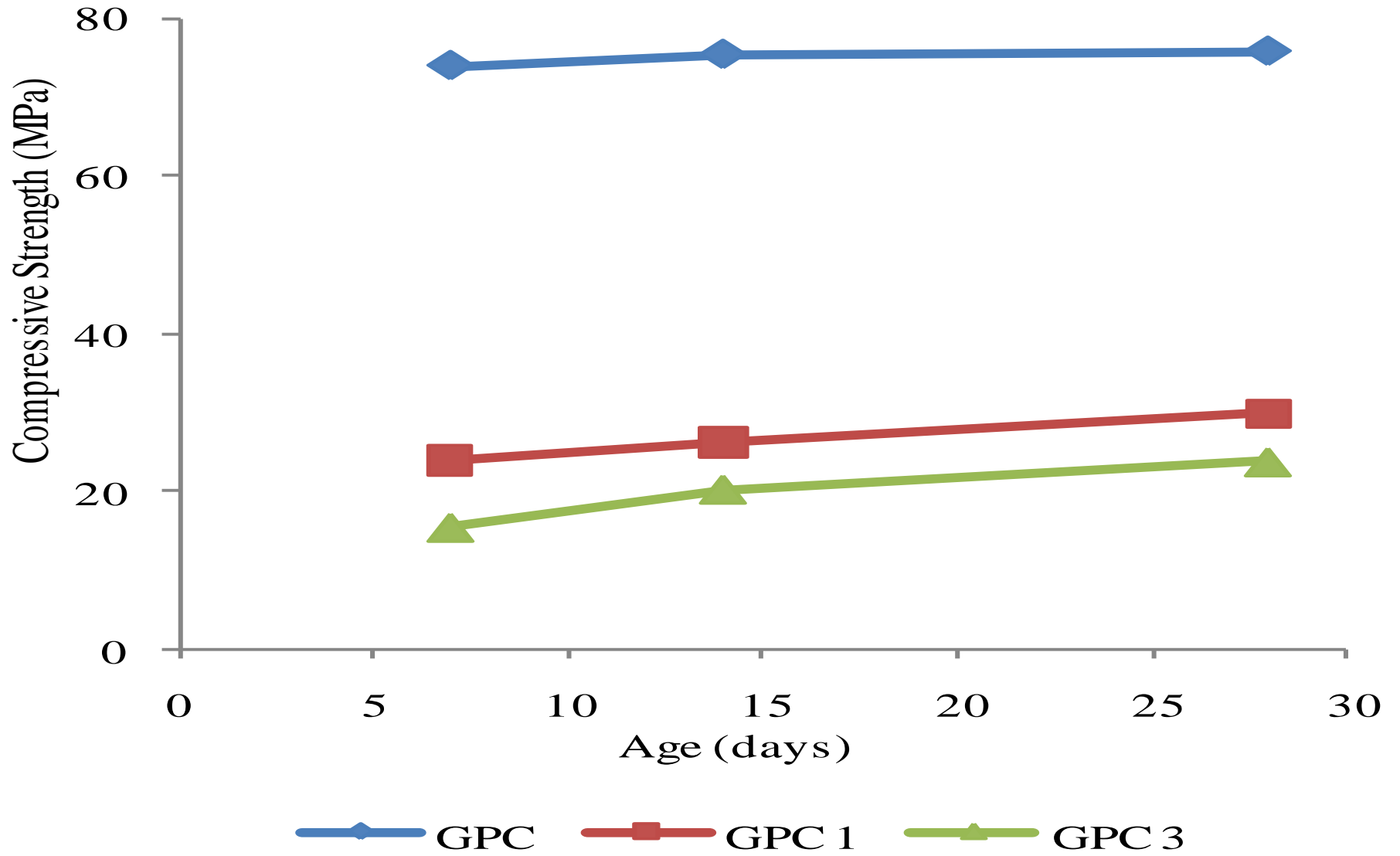

Fig. 3 (c). Heat curing of concrete specimens

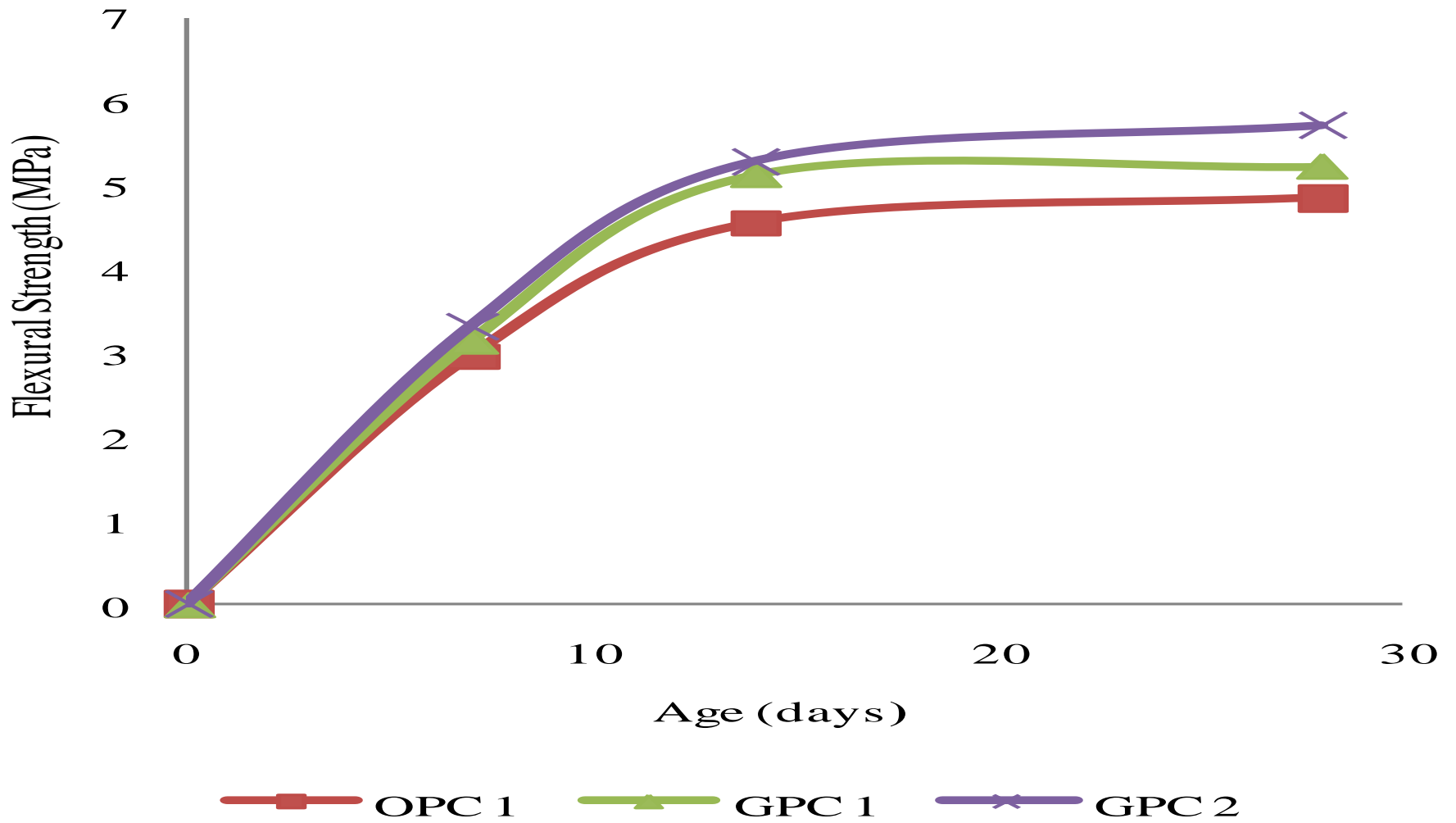

Fig. 4(a): Flexural strength development (series I)

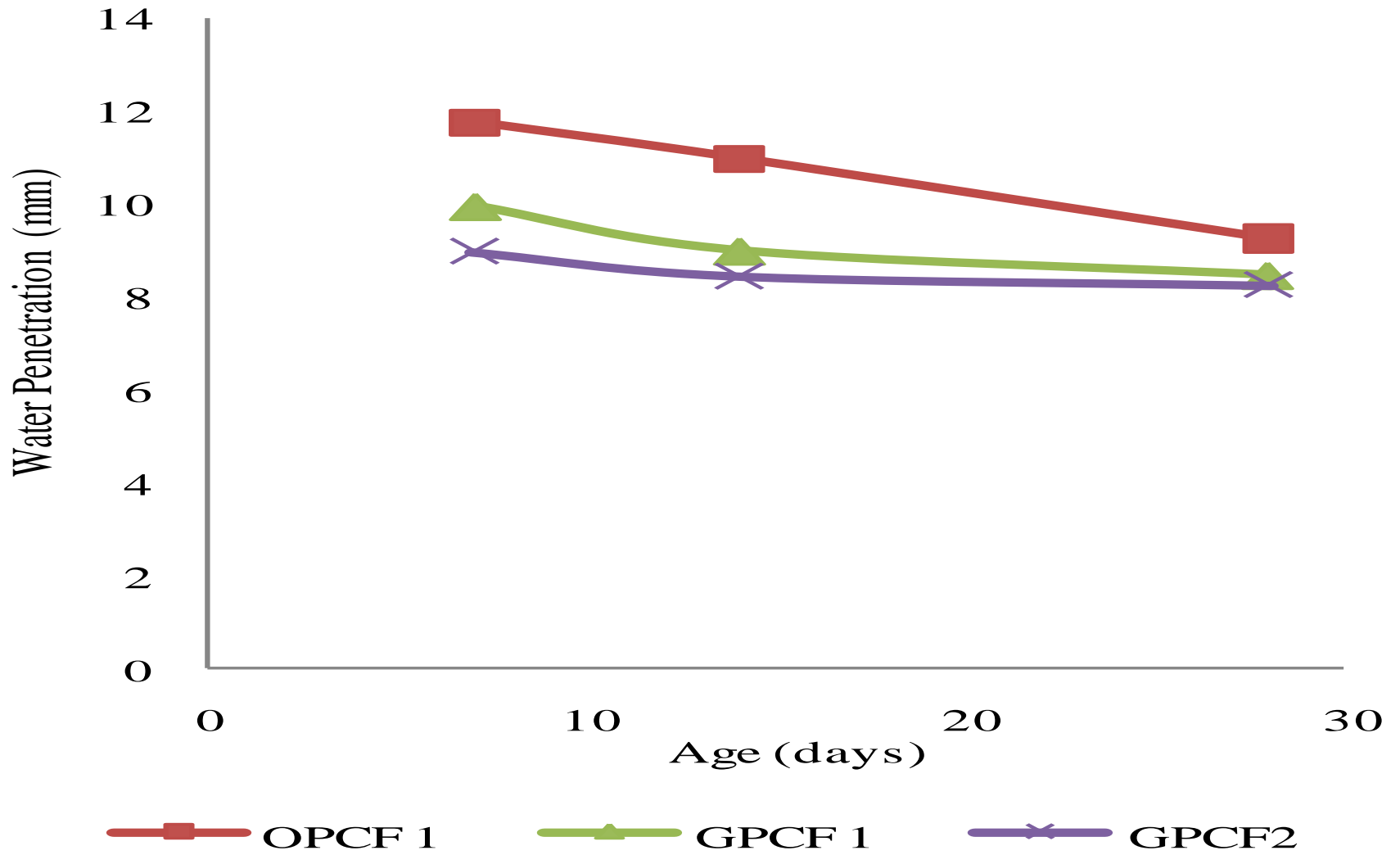

Fig. 6 (b). Water penetration development of concrete series 2

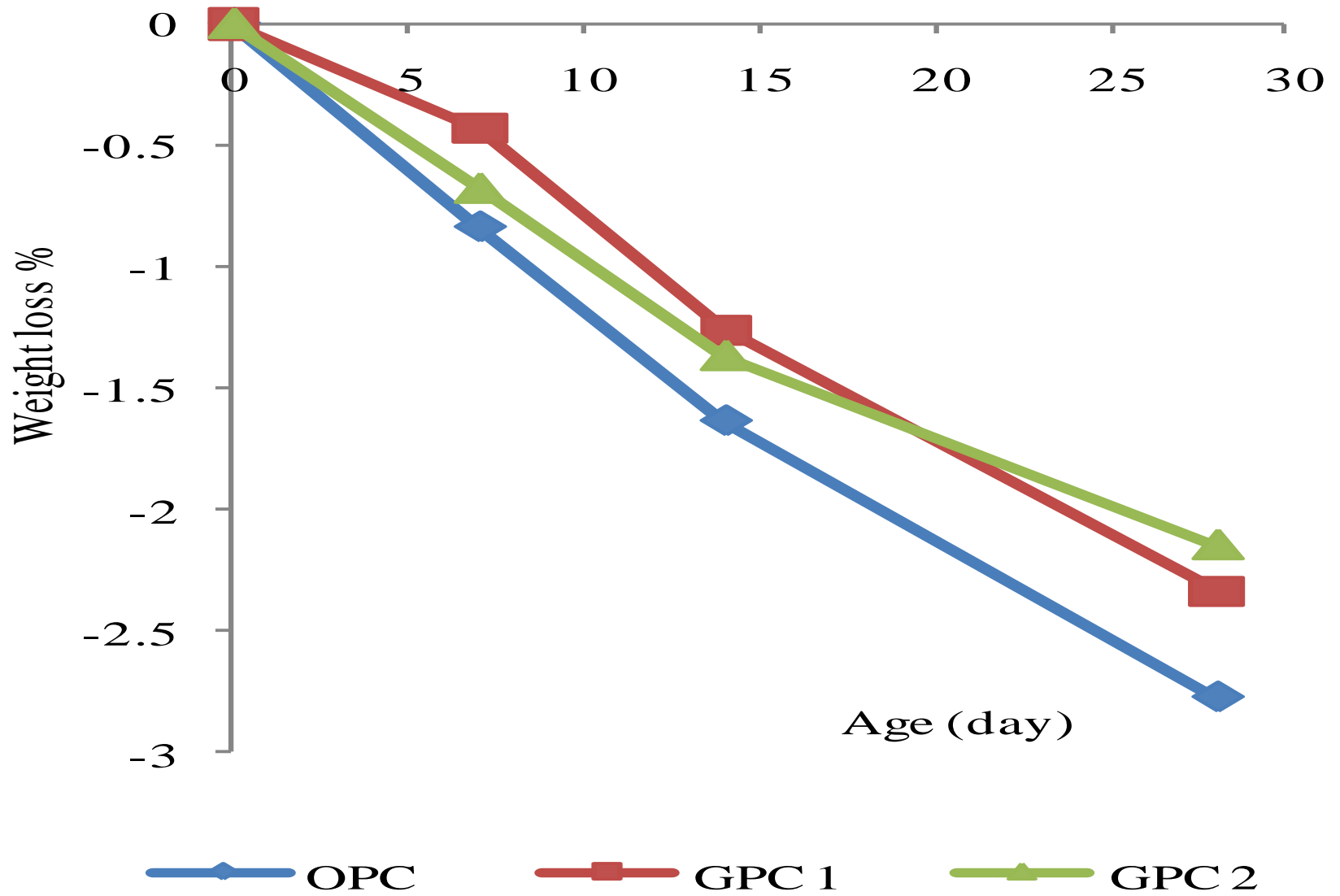

Fig. 7 : Weight changes in geopolymer concrete specimens in 10% of sulphuric acid

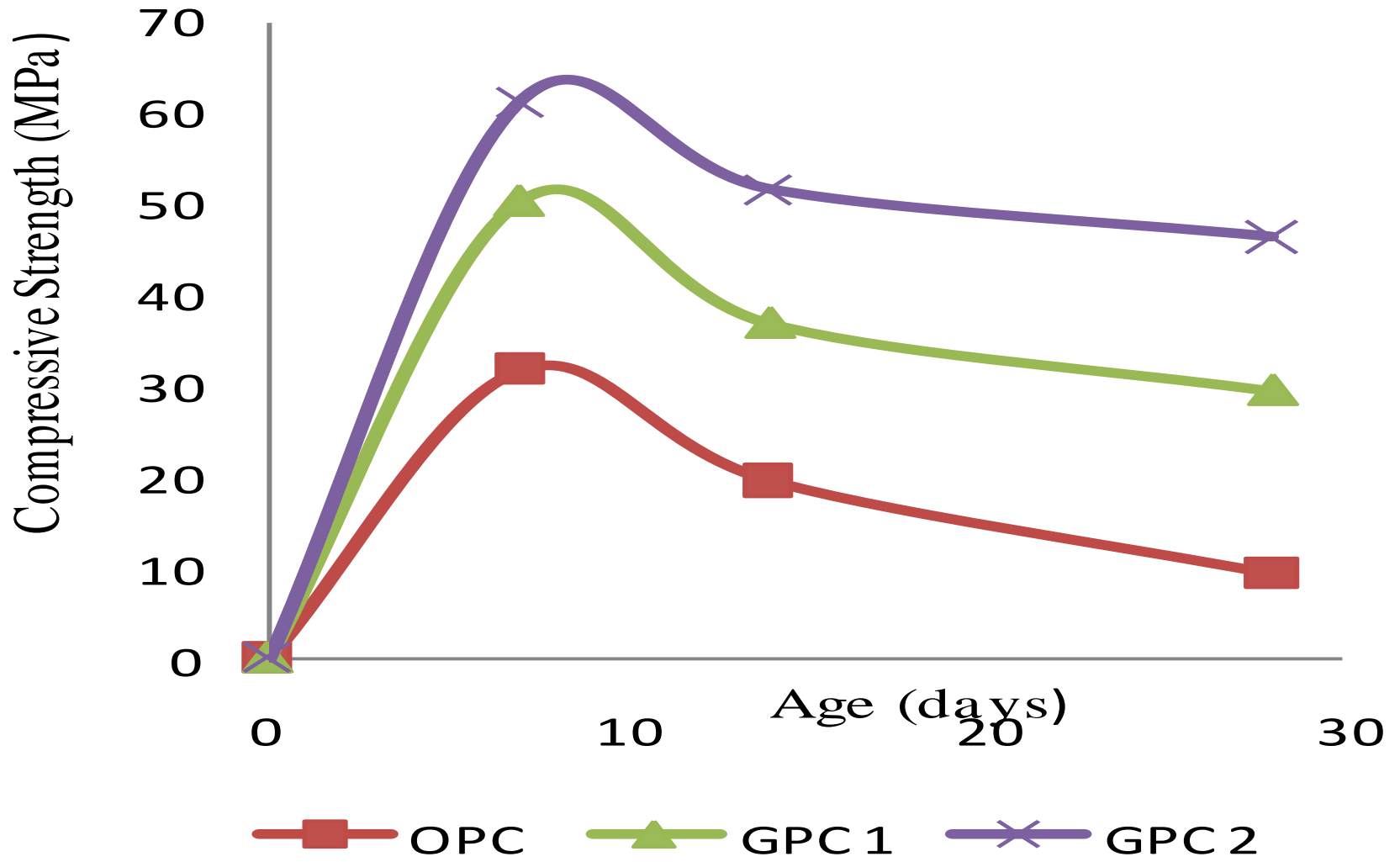
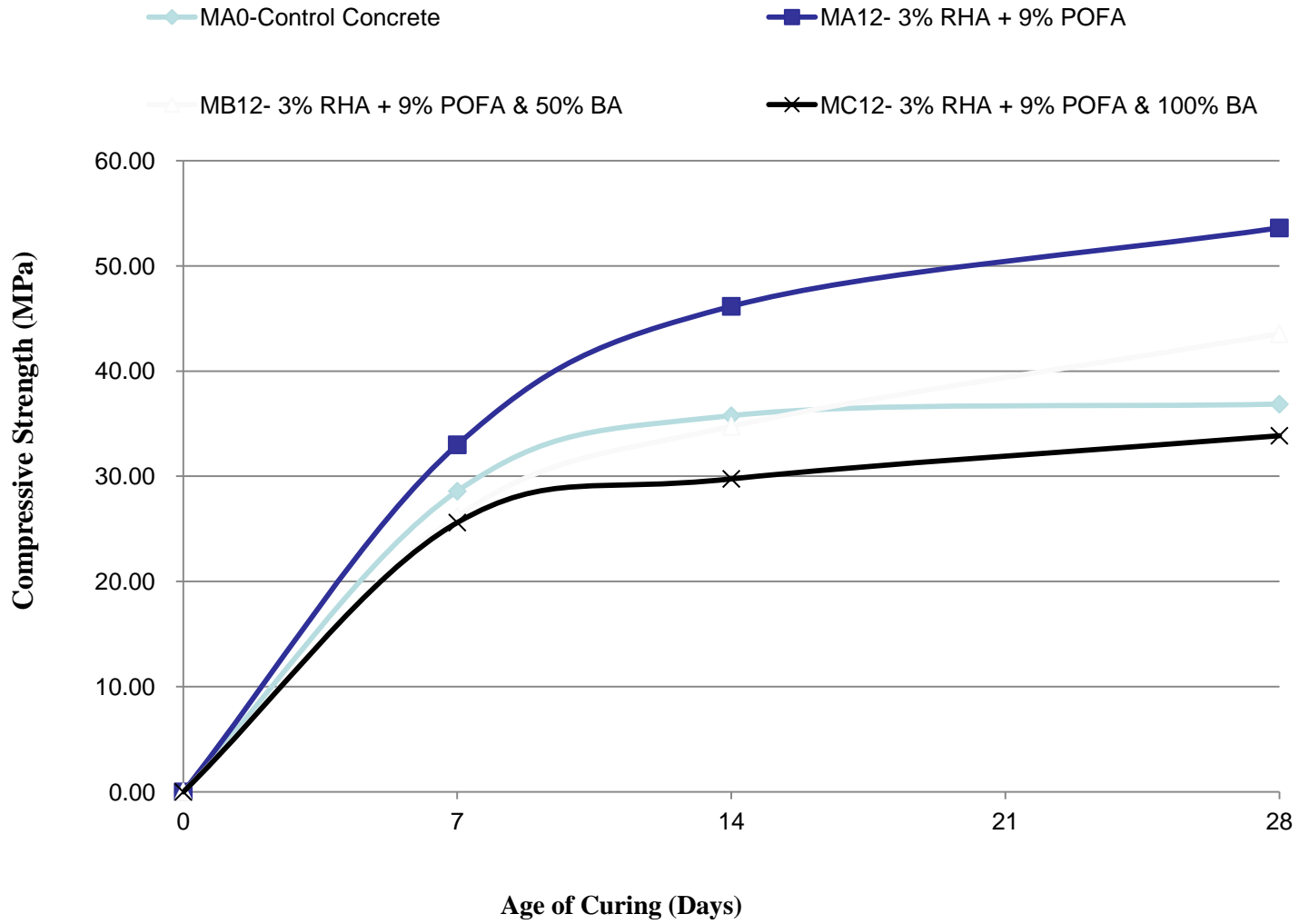

Fig. 8 : Compressive strength change of concrete specimens in 10% of sulphuric acid





RAINBOW SHIELD

*SDN
BHD*



Roofbond Coating System

Imported from Australia for the purpose of extending lifespan of the roof. It features include low dirt pick up, heat reflection, long lasting... and is able to protect the building exterior structure against fungus, rain seepage and UV light.



The Benefits



- Roof are able to
 - Reflects Solar Infrared
 - Reflects visible rays
 - Protected from rain
- Increase the lifespan of the roof over 20 years
- Heat reflected and reduced, power saving
- Beautify the building
- More comfortable interior
- Quick and effective application
- Prevents water seeping
- Prevents oxidization



The Process



Preparation

- Surface cleaning and washing
- Fix and patch all the existing and potential leaking points
- Re-fasten all the losed bolts





The Process



Application of the Roofbond Coating System

- 1st Coat – Fungicide (for cement tile) or Anti Rust Converter (for metal roof)on the rusted area
- 2nd Coat – Sealer
- 3rd Coat – Undercoat
- 4th Coat – Finish Coat





Roof Coating Demo



RAINBOW SHIELD SDN BHD. (359054-J)

Formaly known as Rainbow Roofguard (J) SDN BHD

Protective Coating & Waterproofing Specialist



Roof Coating Demo

Please visit: www.rainbowshield.com.my

SIRIM



SIRIM



Before

After

Batu Pahat Chinese Chamber of Commerce



Before



After



10 Years after Completion!

Kota Tinggi Syarikat Air Johor (S.A.J)



Before

After



Before

After

Kota Tinggi Syarikat Air Johor (S.A.J)



Before

After

Batu Pahat J. K. R.



Before



After



10 Years after Completion!

Johor Bahru Cathedral Sacred Heart of Jesus



Before

After

Batu Pahat

Yew Lee Metal Works Sdn Bhd



Before



After

Johor Bahru Parkson Grand – Holiday Plaza



Before

After

Johor Bahru Parkson Grand – Holiday Plaza

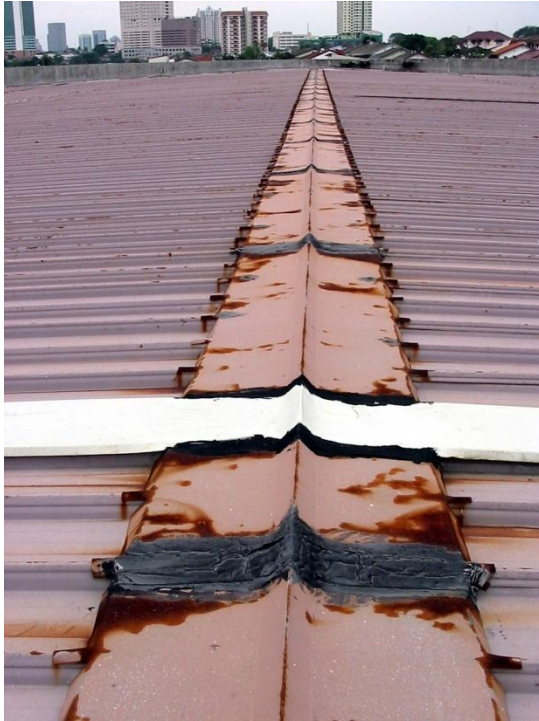

Before

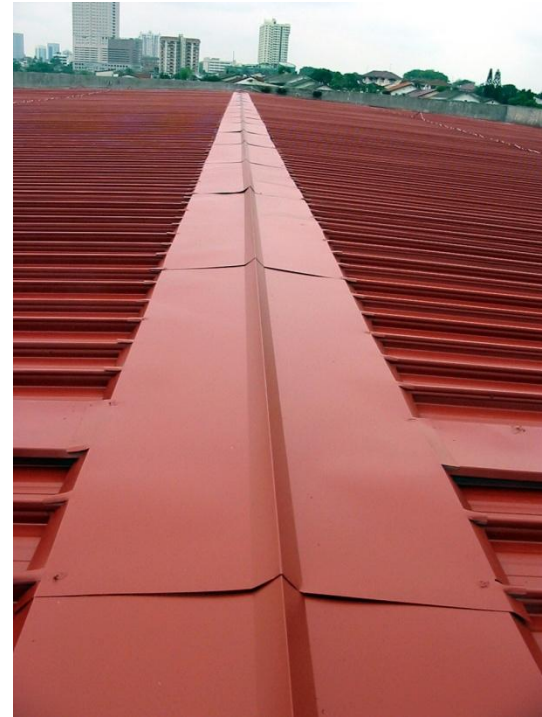

After

Kluang

Temple - Lin Shan Si



Kluang Temple - Lin Shan Si



Before

After

Plus Tol



Before

After

Plus Tol



Before

After

Houses and Bungalows



Before



After

Houses and Bungalows



Before

After



RAINBOW SHIELD

*SDN
BHD*

THERMOBOND

HRC

Keeps you cool - when the heat is on!

Reflect heat to prevent heat from penetrating through, which will allow the building to be cooler.

THERMOBOND H R C



- Air Conditioning costs can be reduced by 20% per annum
- Solar Reflectance of 88%
- Infrared Emittance of 88%
- Ceiling cavity temperature reduced
- Long durability - Thermobond can last at least 10 years
- Low maintenance cost
- Increase the life span of your property.

Typical Home Without Reflective Coatings

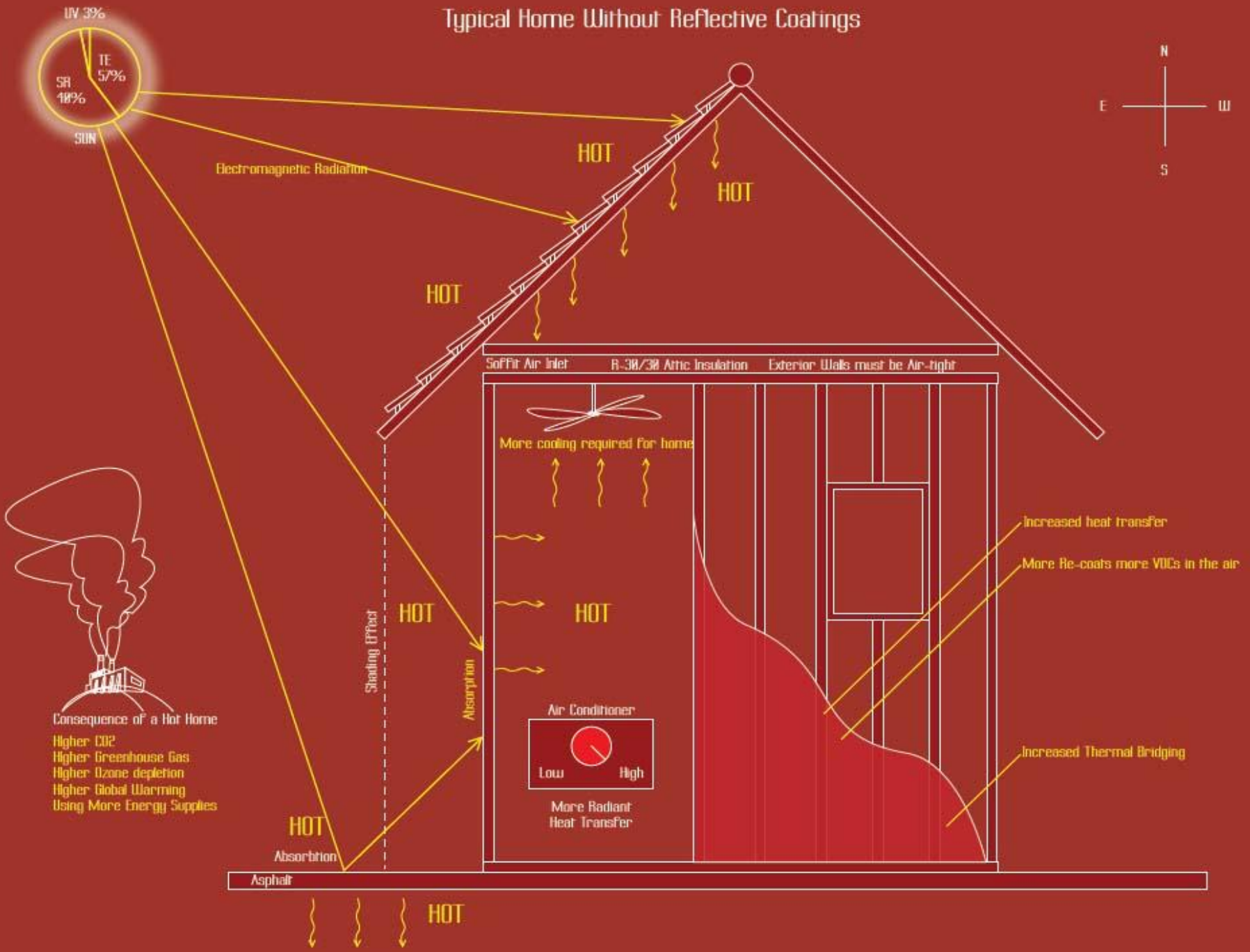

Consequence of a Hot Home
 Higher CO2
 Higher Greenhouse Gas
 Higher Ozone depletion
 Higher Global Warming
 Using More Energy Supplies

Energy Efficiency Thermal Envelope Using Heat Reflective Coatings

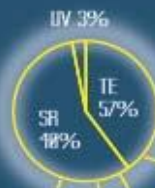

Electromagnetic Radiation

- Desiduous Trees**
- Intercepts solar radiation and converts it to cool air through evapotranspiration
 - Deans and purifies air
 - Absorbs CO₂ (Greenhouse Gas) converts to O₂
 - Stabilizes soil and prevents erosion
 - Sheds leaves during Winter providing warmth

Consequence of a Cool Home

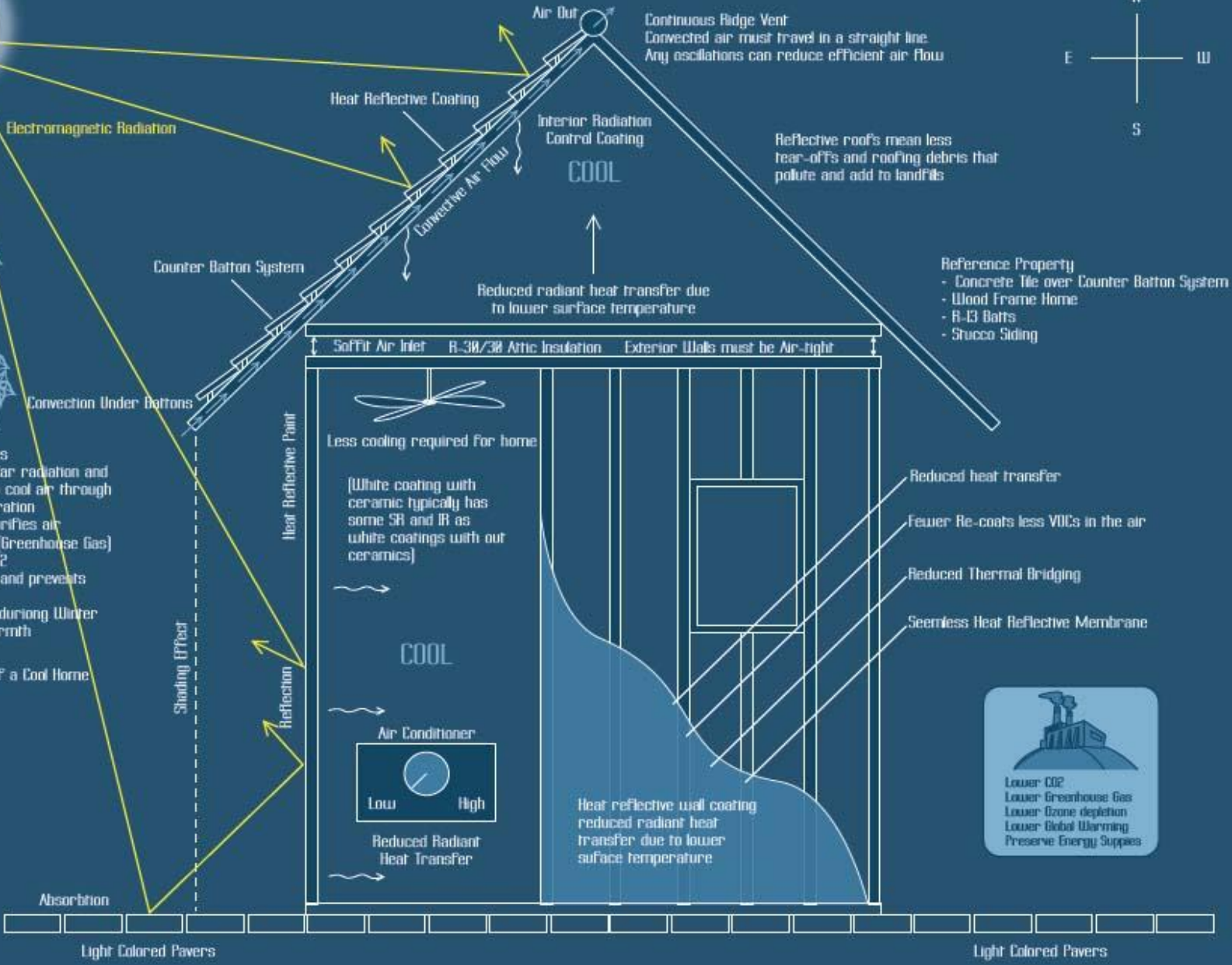

Lower CO₂
 Lower Greenhouse Gas
 Lower Ozone depletion
 Lower Global Warming
 Preserve Energy Supplies

THERMOBOND H R C

Thermal Test





Before



After

THERMOBOND H R C



SHELL Petrol Station



THERMOBOND H R C



Before



After

THERMOBOND H R C



Before



After



Roofbond and Thermobond **Warranty**



5 Years Warranty

for

Non Peel and ***Non Colour
Fade***



彩虹防护镀层有限公司

RAINBOW SHIELD

SDN

BHD

Formally known as RAINBOW ROOFGUARD (J) SDN BHD

Protective Coatings and Waterproofing Specialist

Since 1996



www.rainbowshield.com.my

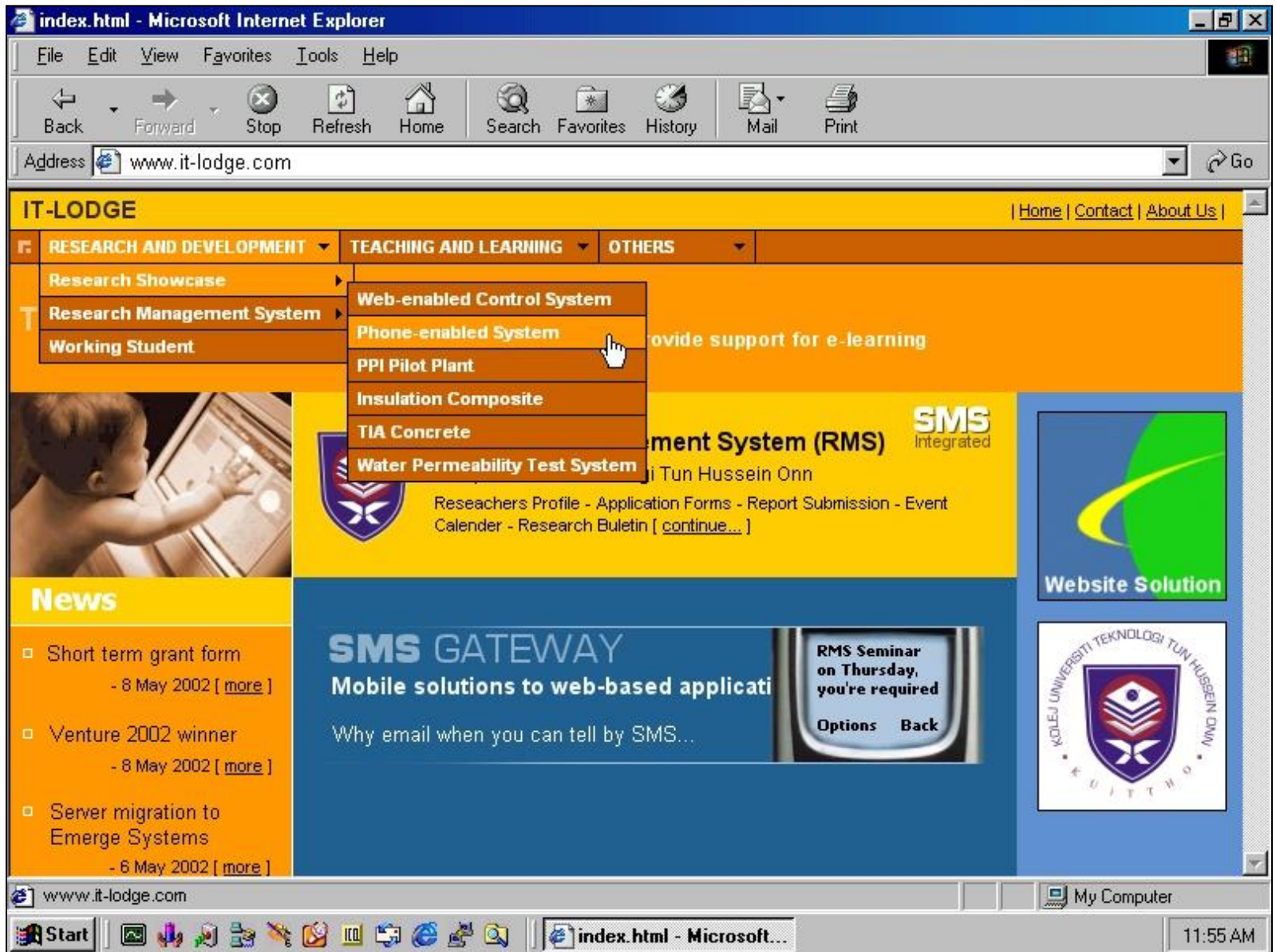

IT-Lodge - bridging digital divide

www.1.net.my



Business Model

	Yr 1 RM'000 (50m ³ production/day)	Yr 2 RM'000 (100m ³ production/day)	Yr 3 RM'000 (200m ³ production/day)	Yr 4 RM'000 (400m ³ production/day)	Yr 5 RM'000 (800m ³ production/day)
Revenue	3,000	6,000	12,000	24,000	48,000
(-) <u>Cost of Goods Sold:</u>					
Raw materials	1,824	3,648	7,296	14,592	29,184
Labour	456	912	1,824	3,648	7,296
Gross Profit	720	1,440	2,880	5,760	11,520
(-) <u>Operating Expenses:</u>					
Sales & Marketing	120	120	120	120	120
Management Staff Salaries	360	360	360	540	810
Rental of Equipment & Land	1,620	1,620	2,350	2,350	3,350
Net Profit	(1,380)	(660)	50	2,750	7,240







Conclusion

- Biomass silica ash and aggregate are exciting renewable & sustainable resources for waterproofing applications.
- Self-compacting concrete (structural and non-structural) are available.
- Precast and cast-in-situ methods should be profitably exploited.
- Small prestressed elements could be a viable IBS solution for single-storey buildings.
- High early strength and self-levelling grout are useful for joints.
- Spray applied coating on blended cementitious polymeric formulation offers enhanced thermal insulation and water resistance on roof and building envelope.
- RM30 million per year business opportunity
- Proposed showcase of PinSpace in UTHM
- Proposed rebranding of 1Malaysia Cabin
- Proposed IP exploitation by www.ashmann.com
- Proposed seed funding from ORICC
- Proposed support for CSM community to be funded by MOSTI CIF



REFERENCES

- **Hardjito, D. and Rangan, B. V.(2005) *Development and Properties of Low-Calcium Fly Ash-based Geopolymer Concrete*, Research Report GC1, Faculty of Engineering, Curtin University of Technology, Perth.**
- **Wallah, S.E. and Rangan, B.V.(2006), *Low-Calcium Fly Ash-Based Geopolymer Concrete: Long-Term Properties*, Research Report GC2, Faculty of Engineering, Curtin University of Technology, Perth.**
- **Sumajouw, M.D.J. and Rangan, B.V.(2006), *Low-Calcium Fly Ash-Based Geopolymer Concrete: Reinforced Beams and Columns*, Research Report GC3, Faculty of Engineering, Curtin University of Technology, Perth.**
- **Rangan, B.V.(2008), *Fly Ash-based Geopolymer Concrete*, Research Report GC4, Curtin University of Technology, Perth.**

Download these four Reports free from espace@curtin



Acknowledgement
CIDB, ORICC
Cradle Fund Sdn Bhd
Junda Realty Sdn Bhd
RECESS Malaysia, UTHM

www.ashmann.com

The contribution of Cheong CL, Stephen Ko and Prof. Rangan are acknowledged.